

Body OEM Unit Dimensions /Mount for Supra S10 Multi-Temp

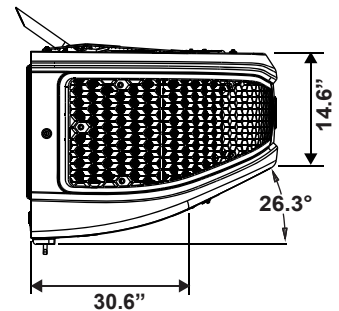

Mounting Bolts (Qty 4)
Diameter: 1/2" - 13
UNC-2A Grade: 5 (SAE)
Length: 3.5" from Mounting Surface

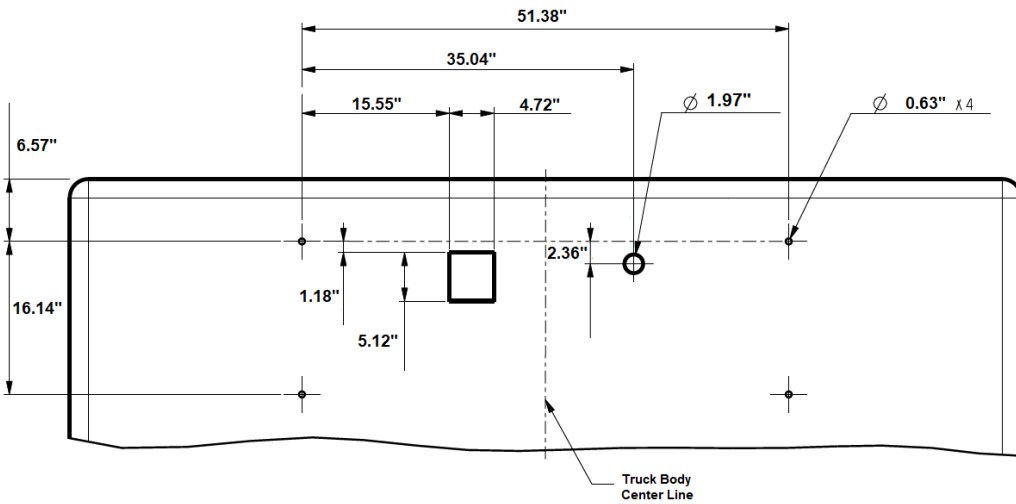
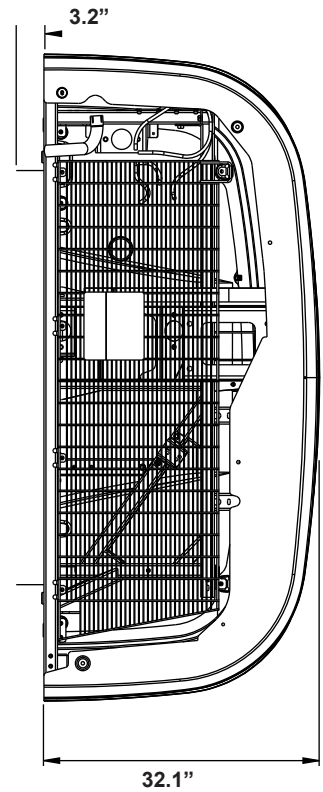
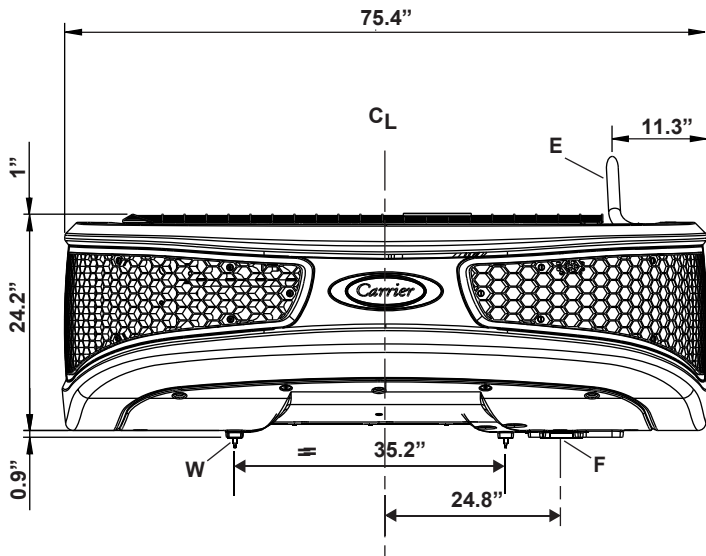
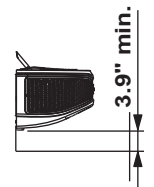

Alternative for recessed body installation

- Key**
 CL = Center Line
 E = Exhaust Pipe
 F = Fuel Line
 W = Water Drain

Unit Weight	
Model	Standby
S10 M/T Host	963 lbs

Carrier Transicold reserves the right to modify this information and model design without prior notice, in line with our policy of continuous improvement of design, quality and performance.

North America
 Carrier Transicold
 700 Olympic Drive Athens,
 GA 30601 USA

Central America and Mexico
 Ejercito Nacional 253-A Piso 5
 Colonia Anahuac
 11320 Mexico, D.F.



Carrier Transicold
 P.O. Box 4805
 Syracuse, NY 13221 USA