

Presentation on a grand-scale

Methos makes optimal use of floor space

Methos refrigerated multidecks allow each corner of a market to be optimally used. They are available in different, freely combinable depths and versions so that markets can be optimally planned and executed.

For all its size, each Methos multideck has a very small footprint. The multideck design fits any modern market architecture and ideally showcases the merchandise. A Methos cannot fail to boost sales.

And the e*cube programme also helps save energy and spare resources.



Excellent display of merchandise



Adaptable

Even 90° external corner units possible



Benefits at a glance

- Excellent display of merchandise
- Exceptionally small footprint
- Particularly high floor space utilisation
- Optimum lighting
- Suitable for all market layouts
- Also available as roll-in cabinet
- Timeless merchandising design

Methos-GD.e*cube:

Low energy consumption, high temperature reliability

Refrigerated multideck with hinged glass doors

The Methos-GD.e*cube is designed for the energy-saving display of refrigerated merchandise. The refrigerated multideck has energy-saving hinged glass doors, energy efficient electronic fans and economical T5 HE fluorescent tubes.

Secure merchandise quality

Hinged doors protect temperature-sensitive food against environmental disturbances and ambient air. They permit ready access for easy

stocking and picking of goods.

The aisles between cabinets remain pleasantly warm, as the cold air cannot escape from the unit. Defrost cycles are also reduced.

Taken together, these features save energy and enhance merchandise safety. The EC fans save additional energy and offer greater functional dependability. Energy-saving T5 HE fluorescent tubes or optimised LED rails further increase the energy-saving potential.

Benefits at a glance

- Significant reduction in energy costs
- Reduced refrigeration load
- High temperature reliability
- Cold aisle effect avoided, hence greater shopper comfort
- Fewer defrost cycles, hence improved food protection

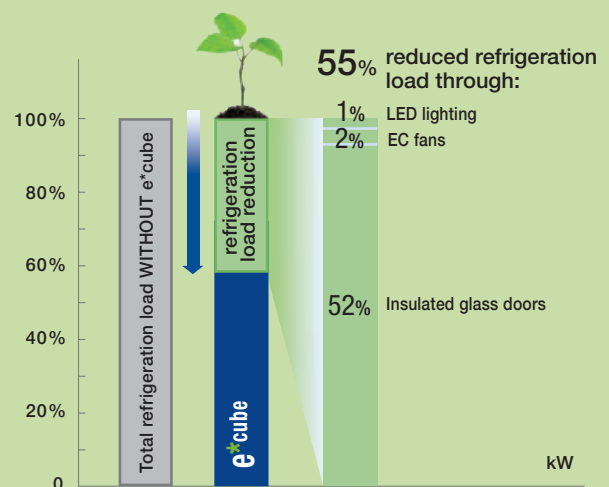
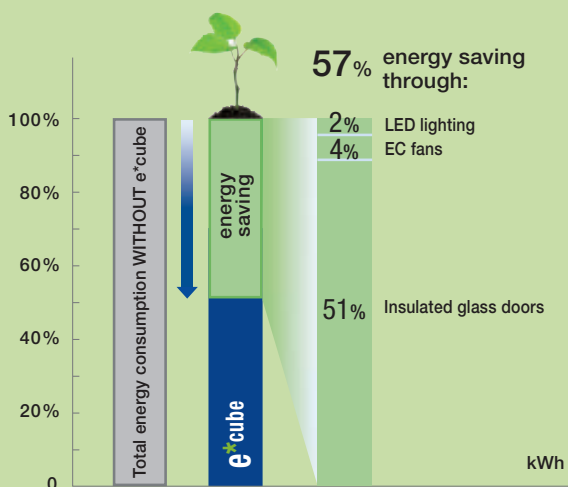

Source: Carrier Lead Design Center

Three door variants for individual customer needs

For each need the solution to match. And: All three variants are virtually identical in their refrigeration technology!

Standard doors

A double insulated hinged glass door with narrow plastic edge section and a narrow inner merchandiser frame in a neutral powder coating (white-aluminium).

Frameless all-glass doors

A double insulated hinged glass door without additional edge section and without inner merchandiser frame – for a modern, elegant overall look.

Frameless all-glass doors Antireflex

A double insulated hinged glass door without additional edge section and without inner merchandiser frame. The glass panes are fitted with antireflection coating - for an almost completely free view of the merchandise.

Standard equipment

- Insulated hinged glass doors
- EC fans (energy-economizing)

Accessory

- LED lighting

Saving potential

- Refrigeration load required approx. 55%
- Total electric energy consumption approx. 57%

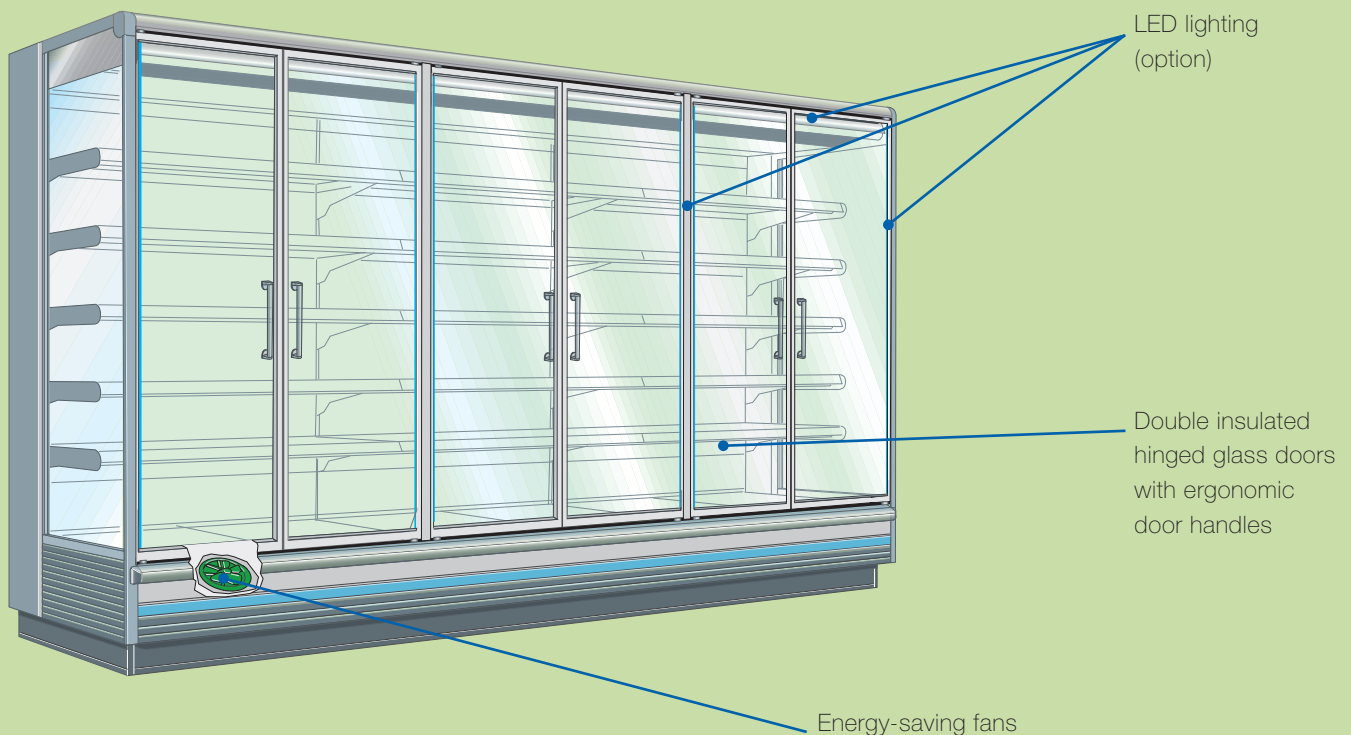

Store planning made easy— sales planning too

Design to enable all combinations

Methos multidecks fit and suit any retail space. Roll-in cabinets, multidecks and crown ends can be freely combined with external and internal corner units and, of course, with other merchandisers in the Evolution 5 product range. All are perfectly matched to create a complete, harmonious overall picture.

The Methos system concept is apparent in each individual module and detail. Need it be added that Carrier also supplies the Methos multidecks in company colours?

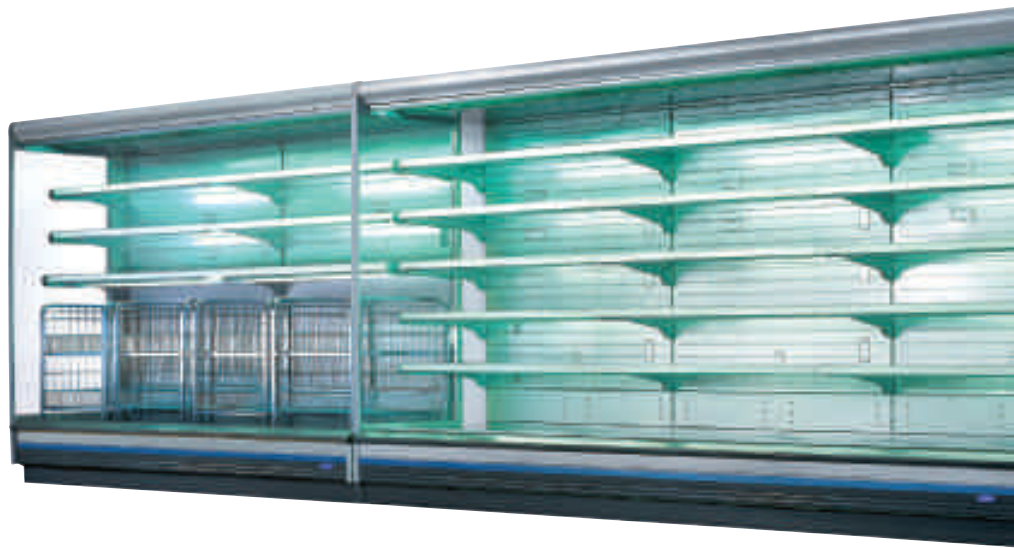

Combined Methos roll-in cabinets and refrigerated multidecks

Visibly connected and physically separated by an intermediate wall

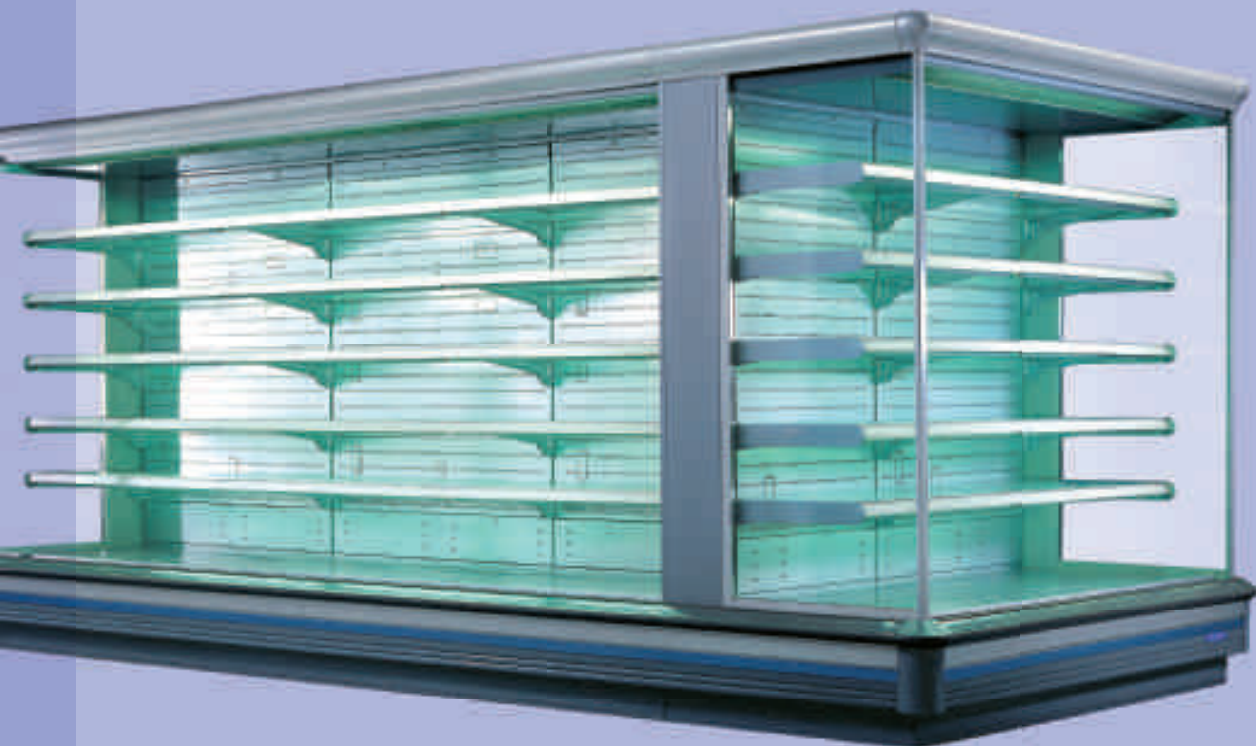

Display area

Here the inner qualities of Methos are there for all to see.

Intelligent solutions down to the last detail



Temperature control

The optional switch and thermometer unit permits temperature controls even with the night blind closed.



Robustness design

The Methos remains unscathed when shopping carts bang into the cabinet front. It is robust and has collision bumpers mounted in just the right places.



Ceaseless product view

Mirrored inserts give the impression of an endless abundance of space for merchandise.



Inclined presentation

Sloped display racks provide an attractive presentation of the products on the bottom display deck. With optional wire dividers, the merchandise is always kept tidy.



High runners

Convenience products on hook displays are always in the customer's optimal field of vision.

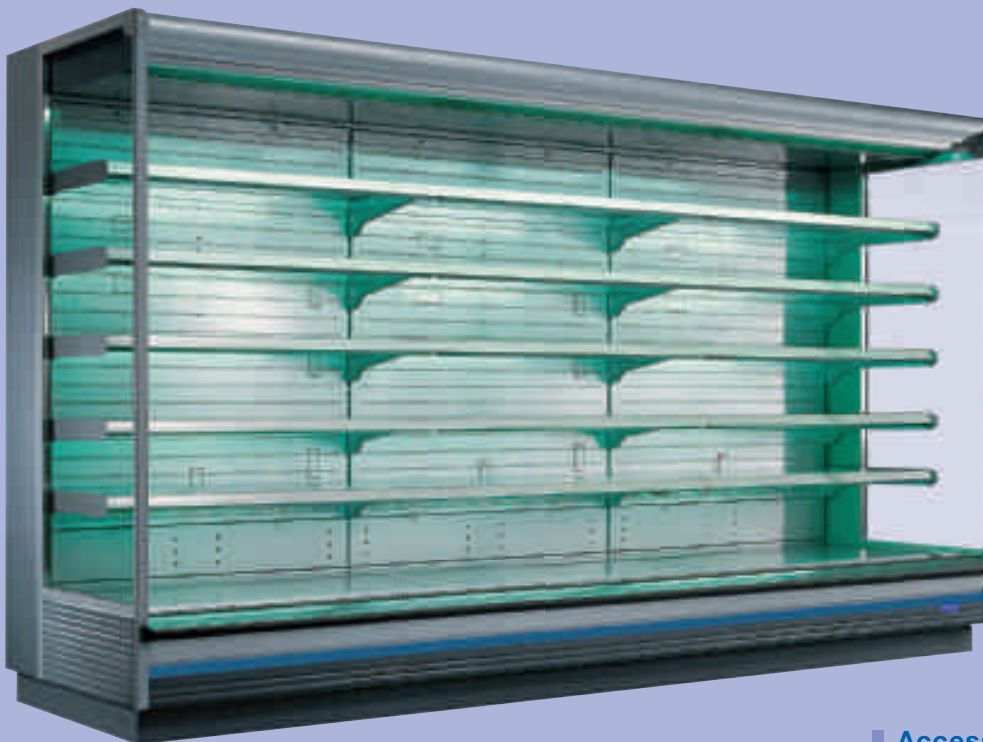

Accessories (examples)

- CO₂ evaporator
- Electronic expansion valves
- D2D defrost system
- UA 300 refrigeration controller

Combinations

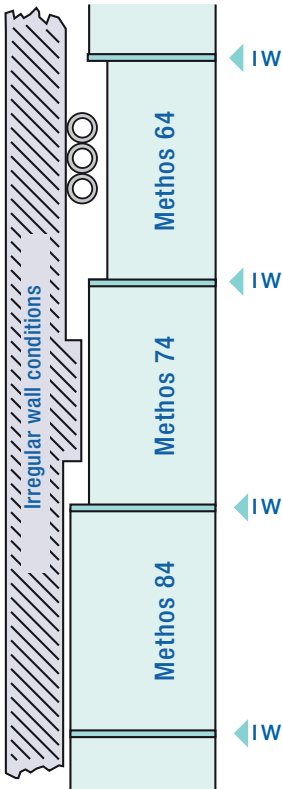

Intermediate and end walls for flexible layout

If, due to prevailing structural conditions, different multideck depths or models are to be combined, intermediate walls will connect them all to form a well-balanced whole. Intermediate walls have all kinds of advantages. They cut purchase and installation costs since each intermediate wall replaces two end walls, while lengthening the width of the display

area. The harmonious transition points between the merchandisers enhance the visual appearance. This creates more freedom for layout planning since it is now even easier to build around utility supply fixtures, columns, and projecting wall sections in the store. All in all, an 'versatile' solution that will have a lasting impact on sales.

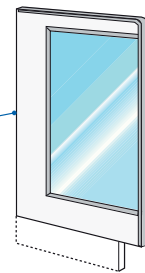
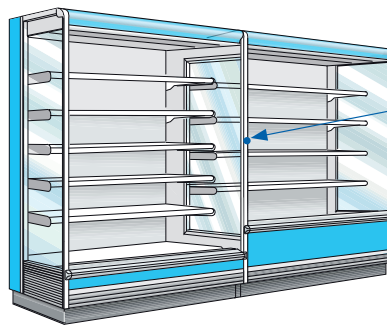

Room to manoeuvre

Intermediate walls for easy creation of any kind of food presentation

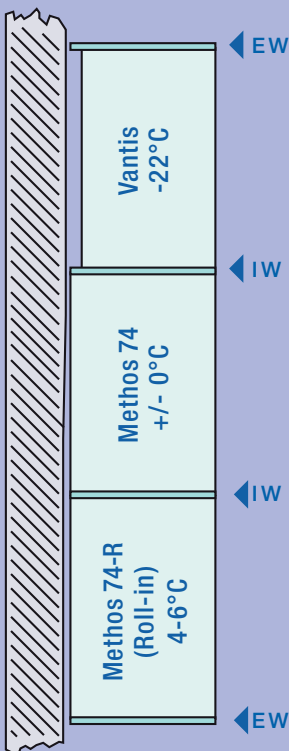

End walls

From open to closed: Side walls offer any and all options for market design. Full-glazed and part-glazed, plain with or without inside mirroring.

Market impressions



Combinations

All merchandisers in the Evolution5 programme fit together perfectly in design and alongside one another.



Display appeal

The product range is presented to customers clearly.



Energy saving

Even when fitted with glass doors, the Methos range creates a customer friendly shopping atmosphere.

Technical data

Methodos

| | | | | |
|--|-----------------|-----------|-----------|----------|
| Type code | Methodos | 64 | B3 | L |
| Name of product line | Methodos | | | |
| Depth of bottom shelf = 60 cm | 64 | | | |
| Cabinet front height = 40 cm | B3 | | | |
| Change code / status = B | L | | | |
| Temperature range = 3 (2/4, 4/6°C) | | | | |
| Detailed information L = height 2,220 mm | | | | |

Methodos refrigerated multidecks: Height 2,040 mm or 2,220 mm, Temperature range 3 (2/4, 4/6 °C)

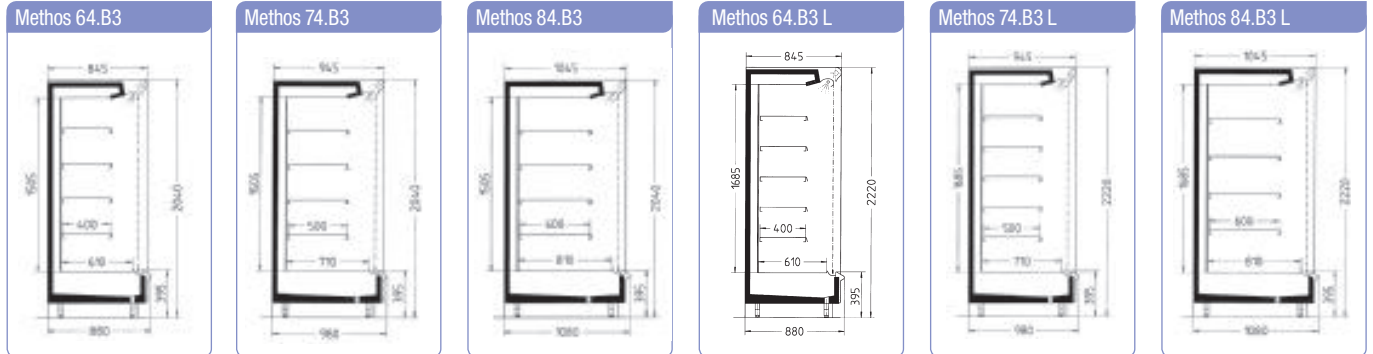

Methodos refrigerated multidecks: Height 2,040 mm or 2,220 mm, Temperature range 4 (0/2 °C)

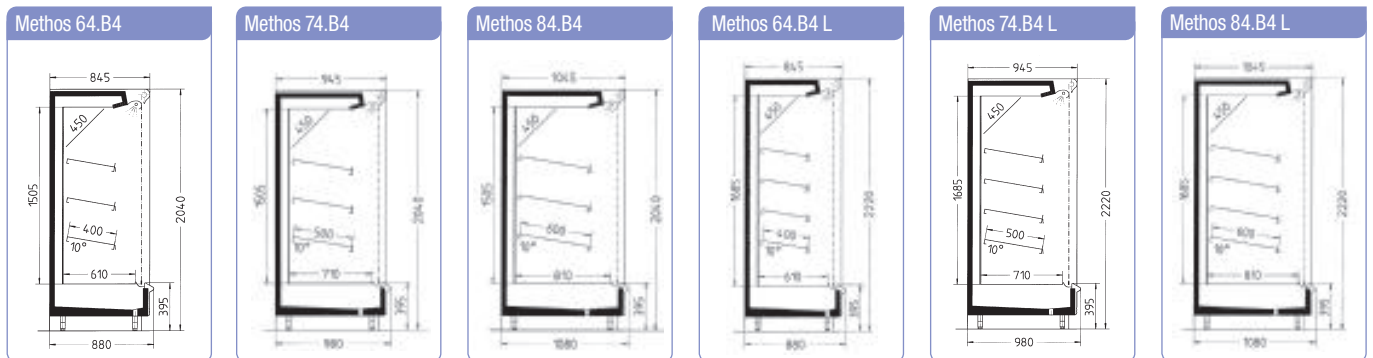

Methodos crown end cabinets: Height 2,040 mm or 2,220 mm, Temperature range 3 (2/4, 4/6 °C), Temperature range 4 (0/2 °C)

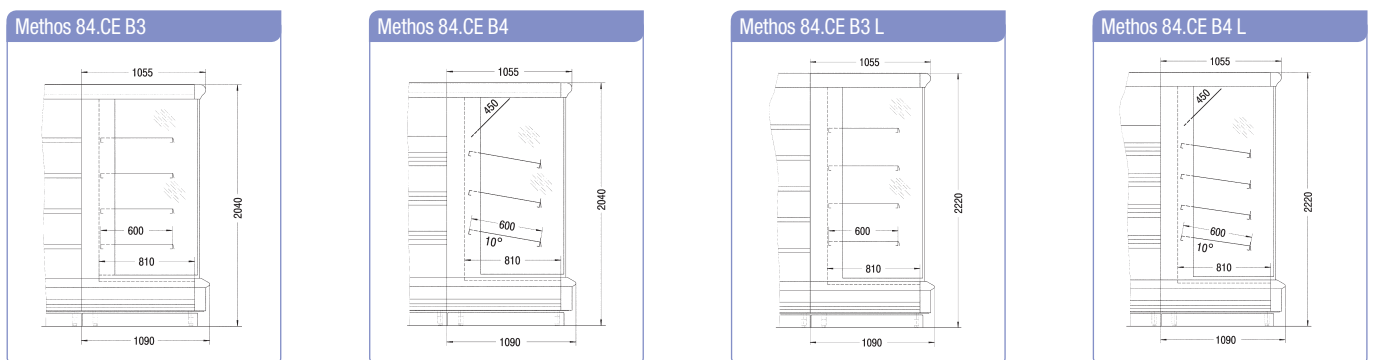

| Methodos | Modules* [mm] | | | |
|---------------------------------|---------------------------------|-------------|-------------|---------------|
| | 125 | 188 | 250 | 375 |
| Length | 1,330 | 1,960 | 2,580 | 3,830 |
| Temperature range | 3 (2/4 to 4/6 °C) or 4 (0/2 °C) | | | |
| Display area | [m ²] | | | |
| Methos 64.B4 / Methos 64.B3 | 2.25 / 2.75 | 3.40 / 4.15 | 4.55 / 5.55 | 6.80 / 8.30 |
| Methos 64.B4 L / Methos 64.B3 L | 2.75 / 3.25 | 4.15 / 4.90 | 5.55 / 6.55 | 8.30 / 9.80 |
| Methos 74.B4 / Methos 74.B3 | 2.75 / 3.40 | 4.15 / 5.10 | 5.55 / 6.80 | 8.30 / 10.15 |
| Methos 74.B4 L / Methos 74.B3 L | 3.40 / 4.00 | 5.10 / 6.00 | 6.80 / 8.05 | 10.15 / 12.05 |
| Methos 84.B4 / Methos 84.B3 | 3.25 / 4.00 | 4.90 / 6.00 | 6.50 / 8.05 | 9.80 / 12.05 |
| Methos 84.B4 L / Methos 84.B3 L | 4.00 / 4.00 | 6.00 / 6.00 | 8.05 / 8.05 | 12.05 / 12.05 |

* Length incl. end walls (40 mm each)

Technical data

Methos Methos-GD.e*cube

| | | | | | |
|--|---------------|--------------|-----------|----------|---------------|
| Type code | Methos | 64-GD | B6 | L | e*cube |
| Name of product line | | | | | |
| Depth of bottom shelf = 60 cm | | | | | |
| Cabinet front height = 40 cm | | | | | |
| GD = Glass door | | | | | |
| Change code / status = B | | | | | |
| Temperature range = 6 (-2/0 °C) | | | | | |
| Detailed information L = height 2,220 mm | | | | | |
| e*cube = energy-saving design | | | | | |

Methos cabinets: Height 2,040 mm or 2,220 mm, Temperature range 5 (-1/+1 °C)

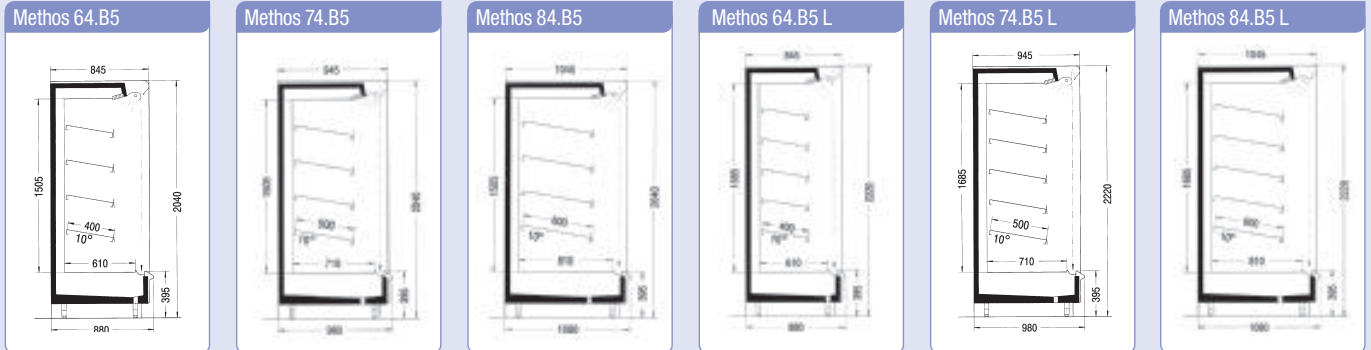

Methos-GD.e*cube cabinets: Height 2,040 mm or 2,220 mm, Temperature range 6 (-2/0 °C)

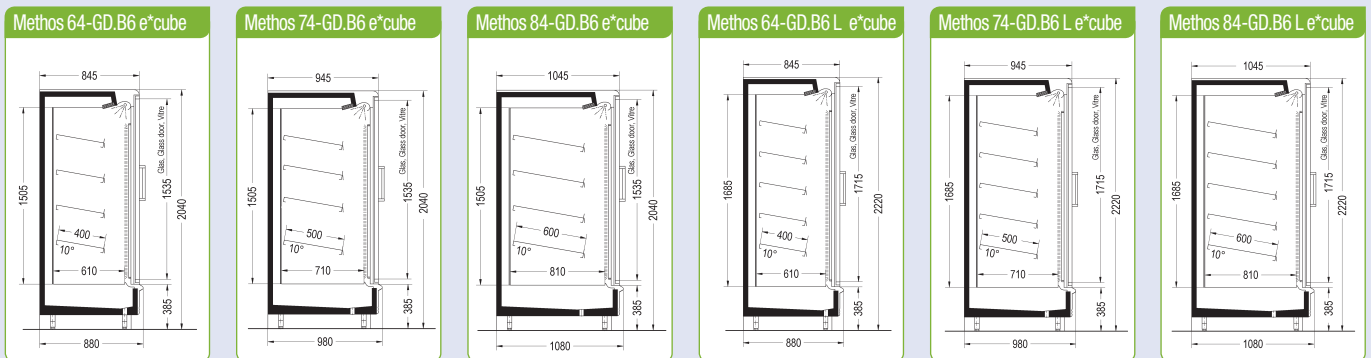

Methos crown end cabinets: Height 2,040 mm or 2,220 mm, Temperature range 5 (-1/+1 °C)

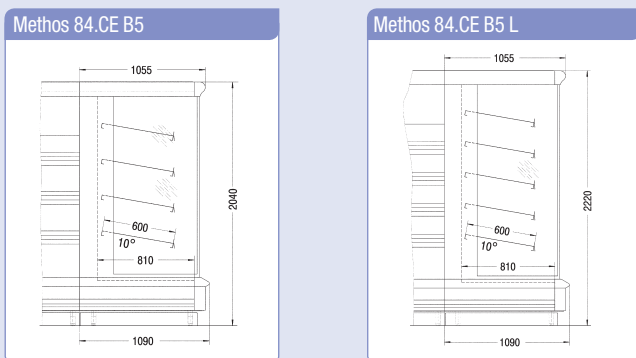

Methos-GD.e*cube crown end cabinets: Height 2,040 mm or 2,220 mm, Temperature range 6 (-2/0 °C)

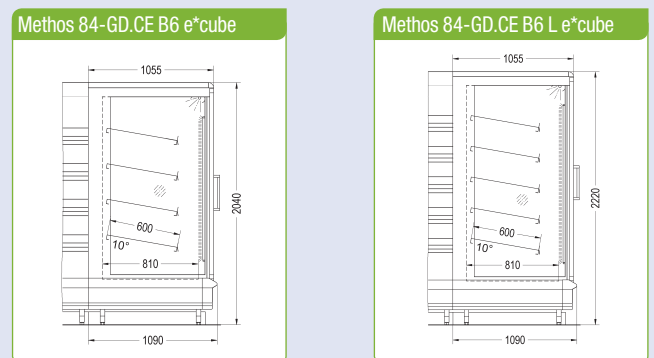

| Methos / Methos-GD.e*cube | Modules* [mm] | | | |
|---|-----------------------------|-------|-------|-------|
| | 125 | 188 | 250 | 375 |
| Length | 1,330 | 1,960 | 2,580 | 3,830 |
| Temperature range | 5 (-1/+1 °C) or 6 (-2/0 °C) | | | |
| Display area | [m ²] | | | |
| Methos 64.B5 / Methos 64-GD.B6 e*cube | 2.75 | 4.15 | 5.55 | 8.30 |
| Methos 64.B5 L / Methos 64-GD.B6 L e*cube | 3.25 | 4.90 | 6.55 | 9.80 |
| Methos 74.B5 / Methos 74-GD.B6 e*cube | 3.40 | 5.10 | 6.80 | 10.15 |
| Methos 74.B5 L / Methos 74-GD.B6 L e*cube | 4.00 | 6.00 | 8.05 | 12.05 |
| Methos 84.B5 / Methos 84-GD.B6 e*cube | 4.00 | 6.00 | 8.05 | 12.05 |
| Methos 84.B5 L / Methos 84-GD.B6 L e*cube | 4.75 | 7.15 | 9.50 | 14.30 |

* Length incl. end walls (40 mm each)

Carrier Commercial Refrigeration offices

Europe

Austria

Carrier Kältetechnik Austria Ges.m.b.H.
1232 Vienna-Inzersdorf
Phone +43 1 66 10 40

Belgium

Carrier Refrigeration Belgium
Division of Carrier Refrigeration Benelux B.V.
1070 Brussel / Bruxelles
Phone +32 3 231 50 93

Bulgaria

Carrier Hladilna Tehnica Klon Bulgaria
1680 Sofia
Phone +359 2 892 60 00

Croatia

Carrier Kältetechnik Austria Ges.m.b.H.
Glavna podružnica Zagreb
10000 Zagreb
Phone +385 1 248 40 00

Czech Republic

Carrier chladicí technika CZ s.r.o.
190 00 Prague 9
Phone +420 281 09 51 11

Denmark

Carrier Refrigeration Denmark A/S
8260 Viby J
Phone +45 86 55 02 55

Finland

Carrier Oy
01610 Vantaa
Phone +358 9 61 31 31

France

Carrier Refrigeration Distribution France SAS
94100 St Maur des Fossés
Phone +33 1 43 97 61 00

Germany

Carrier Kältetechnik Deutschland GmbH
50999 Cologne
Phone +49 2236 601 01

Greece

Carrier Frigel Apostolou SA
10442 Athens
Phone +30 210 519 30 00

Hungary

Carrier Hűtéstechnika Forgalmazó
Magyarország Kft./Carrier Refrigeration
Distribution Hungary Ltd.
1037 Budapest
Phone +36 1 437 05 10

Italy

Carrier Distribution Italy SpA
20016 Pero (MI)
Phone +39 024 88 67 51

Netherlands

Carrier Refrigeration Benelux B.V.
4104 AW Culemborg
Phone +31 345 54 44 44

Norway

Carrier Refrigeration Norway AS
0668 Oslo
Phone +47 23 37 58 40

Poland

Carrier Chłodnictwo Polska Sp. z o.o.
02-673 Warszawa
Phone +48 22 544 01 00

Portugal

Carrier Portugal Lda.
2725-109 Mem Martins
Phone +351 21 424 99 00

Romania

Carrier chladicí technika CZ s.r.o. Praga
Sucursala Bucuresti
023828 Bucharest
Phone +40 212 50 04 49

Russia

Carrier Refrigeration Rus
143581 Moscow
Phone +7 495 933 11 75

Slovakia

Carrier chladiaca technika Slovakia s.r.o.
949 07 Nitra
Phone +421 377 76 40 11

Slovenia

Carrier Kältetechnik Austria Ges.m.b.H.
Podružnica Ljubljana
1000 Ljubljana
Phone +386 1 242 55 23

Spain

Carrier Refrigeración Ibérica SA
08036 Barcelona
Phone +34 93 452 71 84

Sweden

Carrier Refrigeration Sweden AB
422 43 Göteborg
Phone +46 771 33 00 99

Switzerland

Carrier Kältetechnik Schweiz AG
4133 Pratteln
Phone +41 61 816 66 66

United Kingdom & Ireland

Carrier Refrigeration UK Ltd.
OX4 6LB Oxford
Phone +44 1 865 33 77 00

Asia/Pacific

China - CCR Asia HQ

Shanghai 200001
Phone +86 21 23 06 30 00

China

Qingdao Haier-Carrier Refrigeration
Equipment Co. Ltd.
Qingdao 266103
Phone +86 532 88 93 86 38

Hong Kong & Macau

Kowloon
Phone +852 26 94 57 92

India

Carrier Airconditioning and Refrigeration Ltd.
Gurgaon, Hararyana 122001
Phone +91 124 482 55 00

Indonesia

Jakarta Pusat 10650
Phone +622 1 42 87 87 33

Korea

Songdo, Incheon
Phone +82 32 835 61 35

Malaysia

46710 Subang jaya, Selangor Darul Ehsan
Phone +603 802 47 77 88

Singapore

Singapore 608926
Phone +65 65 67 55 22

Taiwan

Taipei City
Phone +886 2 279 75 56 77 22

Thailand

Bangkok 10510
Phone +66 2 517 20 00

Vietnam

Ho Chi Minh City
Phone +84 8 39 31 47 00

Hanoi

Phone +84 4 38 24 76 84

Middle East

Middle East

Carrier Middle East Ltd.
Dubai, U.A.E
Phone: +971 44 19 90 00

Other Global Offices

Latin America & Caribbean

Phone +1 954 299 04 18

www.carrier-refrigeration.com
www.carrier.com

