



UNITED
TECHNOLOGIES
CARRIER
TRANSCOLD

Carrier Transicold Division
Carrier Corporation
P.O. Box 4805
Syracuse, New York 13221

THIS DOCUMENT IS THE PROPERTY OF CARRIER CORPORATION
AND IS DELIVERED UPON THE EXPRESS CONDITION THAT THE
CONTENTS WILL NOT BE DISCLOSED OR USED WITHOUT CARRIER

SUBMISSION OF THESE DRAWINGS OR DOCUMENTS
DOES NOT CONSTITUTE PART PERFORMANCE OR
ACCEPTANCE OF CONTRACT

UNIT PREPARATION:

TOP BUMPER:

- 1.0 REMOVE RUBBER PLUGS (2) FROM TOP REAR FRAME POSTS. DISCARD PLUGS.
- 2.0 REMOVE SCREW AND RIVNUT ATTACHING AIR CLEANER BRACKET (AS INDICATED) USING 3/8 DRILL BIT, DISCARD SCREW AND RIVNUT.

BOTTOM BUMPER:

- 1.0 REMOVE SCREW AND RIVNUT (AS INDICATED) ATTACHING RADIATOR SHROUD, RETAIN SCREW, DISCARD RIVNUT.
- 2.0 OPEN MICRO DOOR BY REMOVING (2) SCREWS (AS INDICATED), RETAINING SCREWS, REMOVE (2) RIVNUTS FROM FRAME USING 3/8 DRILL BIT. DISCARD RIVNUTS.

NOTE: IF TRAILER HAS MOUNTING BOLTS PROTRUDING FROM THE FRONT WALL, THEN ALL UNIT PREPARATION AND BUMPER INSTALLATION MUST BE DONE WITH THE UNIT DETACHED FROM THE TRAILER (OTHERWISE THE TRAILER STUDS WILL NOT ALLOW THE BUMPERS TO SLIDE DOWN INSIDE THE UNIT FRAME).

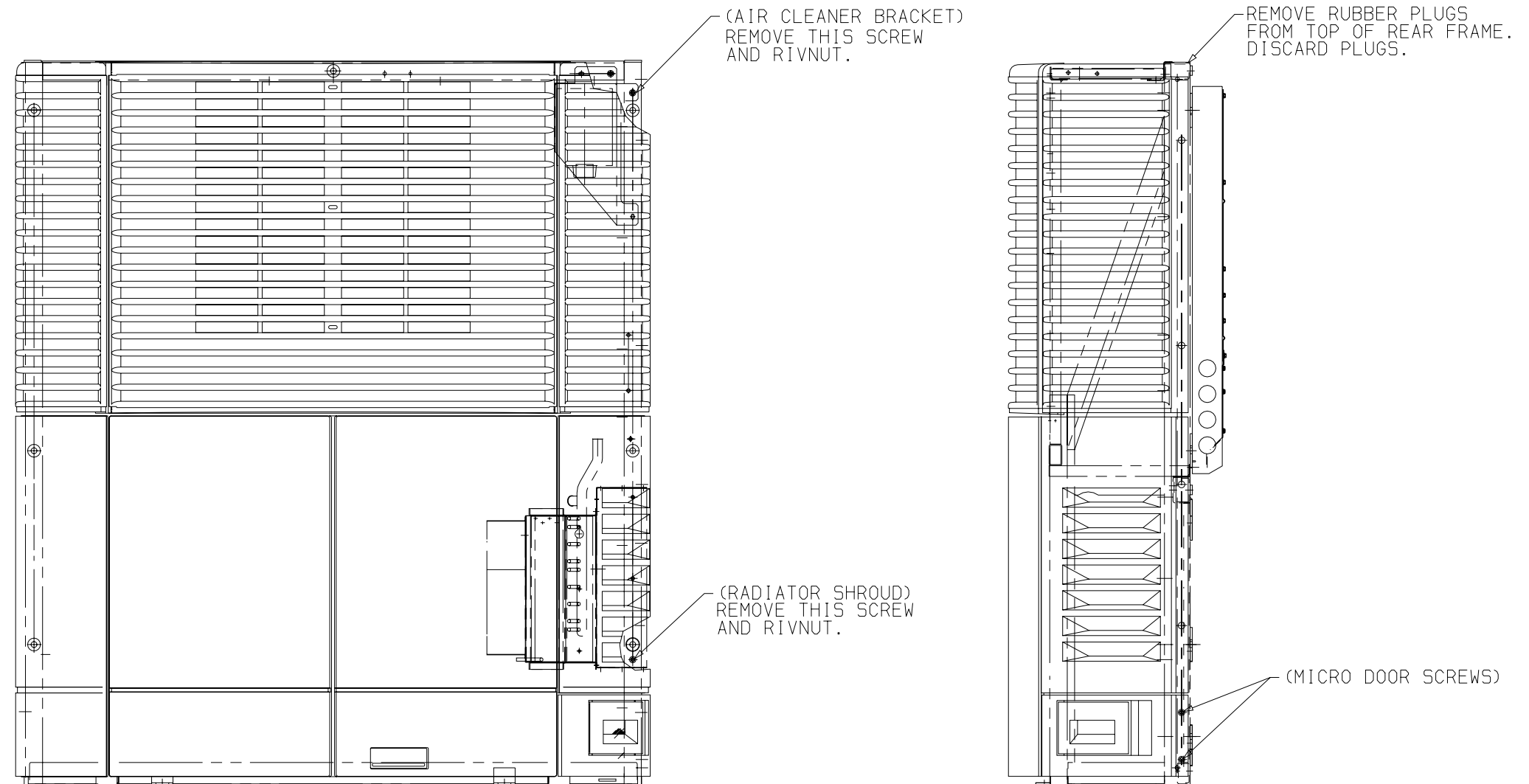

D	UPDATED SHEET INDEX. SEE SHEETS 2 AND 3 PER PCA72N2216P07.				ZMG	15 MAY 2007
C	UPDATED SHEET INDEX. SEE SHEETS 2 AND 3 PER PCA72N2246P04.				ZMG	AUG 25, 2004
B	UPDATED SHEET INDEX; SEE SHEET 3 PER PCA728039G				DLD	09/17/98
A	REVISED NOTE 2.0 "DISCARD SCREW" WAS "RETAIN SCREW".				MED	05/06/97
-	INITIAL RELEASE PER NPR727217GN				MED	02/27/97
SYM	REVISION RECORD	ENGRG.	DATE	APPLICATION ENGRG.	DATE	DRAWN BY DATE

SUPERSEDES

TITLE

INSTALLATION INSTRUCTIONS
UNIT BUMPER

SHEET INDEX	REV	D	D	D
	SHEET	1	2	3
DRAWING NO. 98-03176		REV D		
SHEET 1 OF 3				



UNITED
TECHNOLOGIES
CARRIER
TRANSICOLD

Carrier Transicold Division
Carrier Corporation
P.O. Box 4805
Syracuse, New York 13221

THIS DOCUMENT IS THE PROPERTY OF CARRIER CORPORATION
AND IS DELIVERED UPON THE EXPRESS CONDITION THAT THE
CONTENTS WILL NOT BE DISCLOSED OR USED WITHOUT CARRIER

SUBMISSION OF THESE DRAWINGS OR DOCUMENTS
DOES NOT CONSTITUTE PART PERFORMANCE OR
ACCEPTANCE OF CONTRACT

INSTALLATION PROCEDURE:

TOP BUMPER:

- *NOTE: BOTH UPPER SIDE DOORS MUST BE OPENED TO CLEAR J-LATCHES FROM THE FRAME PRIOR TO INSTALLING BUMPER ASSEMBLY.
- 1.0 REMOVE (4) RUBBER PLUGS FROM BUMPER ASSY (AS INDICATED).
 - 2.0 INSTALL BUMPER ASSY BY SLIDING BUMPER CHANNELS INTO TOP OF REAR FRAME TUBES.
 - 3.0 USING BUMPER AS A TEMPLATE, DRILL (2) 7/16 DIA HOLES THRU EACH CONDENSER SUPPORT.
 - 4.0 INSTALL SPACERS (IT.18) QTY.2, BETWEEN BOTTOM OF BUMPER ASSY AND TOP OF EACH CONDENSER SUPPORT.
 - 5.0 INSTALL SCREWS (IT.6) QTY.2, WASHERS (IT.10) QTY.2, TO TOP OF BUMPER ASSY THRU SPACER AND CONDENSER SUPPORTS.
INSTALL WASHER (IT.10) QTY.2 AND LOCKNUT (IT.8) QTY.2.
 - 6.0 DO NOT FULLY TIGHTEN HARDWARE UNTIL UNIT IS INSTALLED ON TRAILER.
 - 7.0 ONCE BUMPERS ARE IN PLACE, INSTALL UNIT ON TRAILER USING NORMAL MOUNTING HARDWARE TO TIGHTEN THE BUMPER AND UNIT TO TRAILER.
 - 8.0 FULLY TIGHTEN BUMPER HARDWARE FROM STEP 6.0.

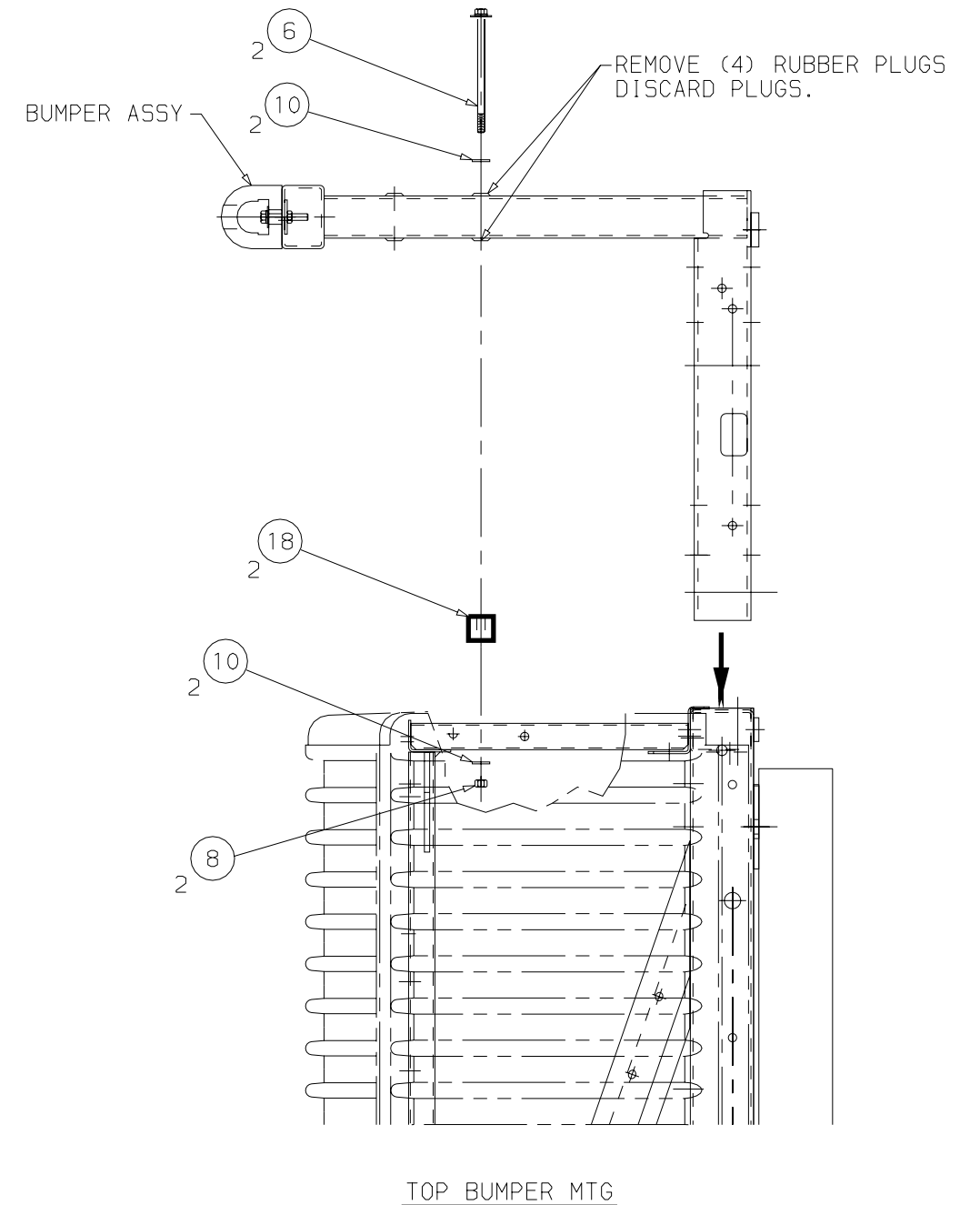
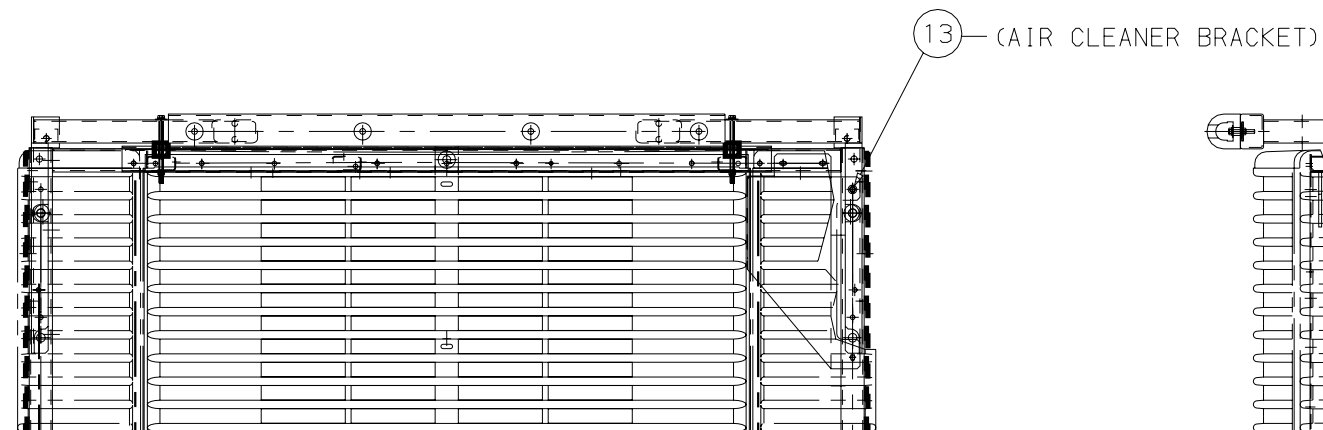
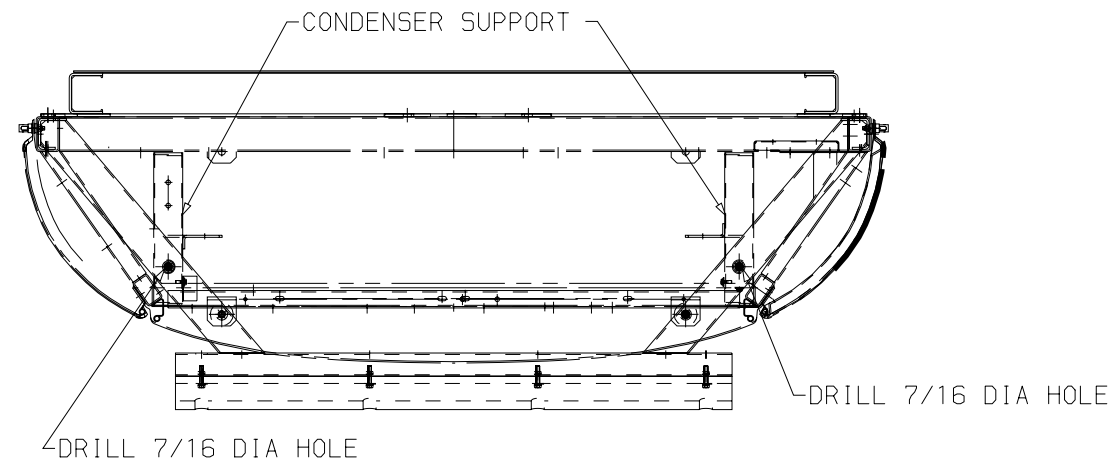

NOTE: IF TRAILER HAS MOUNTING BOLTS PROTRUDING FROM THE FRONT WALL, THEN ALL UNIT PREPARATION AND BUMPER INSTALLATION MUST BE DONE WITH THE UNIT DETACHED FROM THE TRAILER (OTHERWISE THE TRAILER STUDS WILL NOT ALLOW THE BUMPERS TO SLIDE DOWN INSIDE THE UNIT FRAME).

18	48-60072-00	SPACER	2
13	34-00918-08	SCREW, HEX WASH 1/4-20 X 1.00	1
10	34-00366-13	WASHER, PLAIN 3/8	4
8	34-00361-13	NUT, SELF LOCK 3/8-16	2
6	34-00304-40	SCREW, CAP HXHD 3/8-16 X 5.00 LG.	2
ITEM	PART NO.	DESCRIPTION	
ABOVE ITEMS SUPPLIED WITH KIT P/N.: 76-00524-00			REQ.

D	PICTORIALLY UPDATED BUMPER ASSY PER PCA72N2216P07				ZMG	15 MAY 2007
C	PICTORIALLY UPDATED BUMPER ASSY PER PCA72N2246P04.				ZMG	AUG 25, 2004
A	ADDED ITEM 13.				MED	05/06/97
-	INITIAL RELEASE PER NPR727217GN				MED	02/27/97
SYM	REVISION RECORD	ENGRG.	DATE	APPLICATION ENGRG.	DATE	DRAWN BY DATE

SUPERSEDES

TITLE

INSTALLATION INSTRUCTIONS
UNIT BUMPER

DRAWING NO.

98-03176
SHEET 2 OF

REV

D



UNITED TECHNOLOGIES CARRIER TRANSCOLD

Carrier Transicold Division
Carrier Corporation
P.O. Box 4805
Syracuse, New York 13221

THIS DOCUMENT IS THE PROPERTY OF CARRIER CORPORATION AND IS DELIVERED UPON THE EXPRESS CONDITION THAT THE CONTENTS WILL NOT BE DISCLOSED OR USED WITHOUT CARRIER

SUBMISSION OF THESE DRAWINGS OR DOCUMENTS DOES NOT CONSTITUTE PART PERFORMANCE OR ACCEPTANCE OF CONTRACT

INSTALLATION PROCEDURE:

BOTTOM BUMPER:

*NOTE: BOTH LOWER SIDE DOORS MUST BE OPENED TO CLEAR J-LATCHES FROM THE FRAME PRIOR TO INSTALLING BUMPER ASSEMBLY.

- 1.0 REMOVE (4) RUBBER PLUGS FROM BUMPER ASSY (AS INDICATED).
- 2.0 INSTALL BUMPER ASSY BY SLIDING BUMPER CHANNELS INTO BOTTOM OF REAR FRAME TUBES.
- 3.0 ALIGN HOLES IN BUMPER ASSY WITH HOLES IN PALLET MOUNTING TABS.
- 4.0 INSTALL SPACERS BETWEEN TOP OF BUMPER ASSY AND BOTTOM OF EACH PALLET MOUNTING TAB. ON UNITS BUILT IN AUGUST 1998 OR EARLIER THE SMALL (IT.15) AND LARGE (IT.14) SPACERS MUST BE STACKED TOGETHER. ON UNITS BUILT SEPTEMBER 1998 OR LATER USE ONLY THE LARGE (IT.14) SPACER AND DISCARD THE SMALL (IT.15) ONES.
- 5.0 INSTALL SCREWS (IT.4) QTY.2, WASHERS (IT.10) QTY.2 THRU BOTTOM OF BUMPER ASSY, SPACER AND PALLET MTG TABS. INSTALL WASHER (IT.10) QTY.2 AND LOCKNUT (IT.8) QTY.2.
- 6.0 INSTALL RIVNUTS (IT.16).
- 7.0 DO NOT FULLY TIGHTEN HARDWARE UNTIL UNIT IS INSTALLED ON TRAILER.
- 8.0 ONCE BUMPERS ARE IN PLACE, INSTALL UNIT ON TRAILER USING NORMAL MOUNTING HARDWARE TO TIGHTEN THE BUMPER AND UNIT TO TRAILER.
- 9.0 FULLY TIGHTEN BUMPER HARDWARE FROM STEP 7.0.

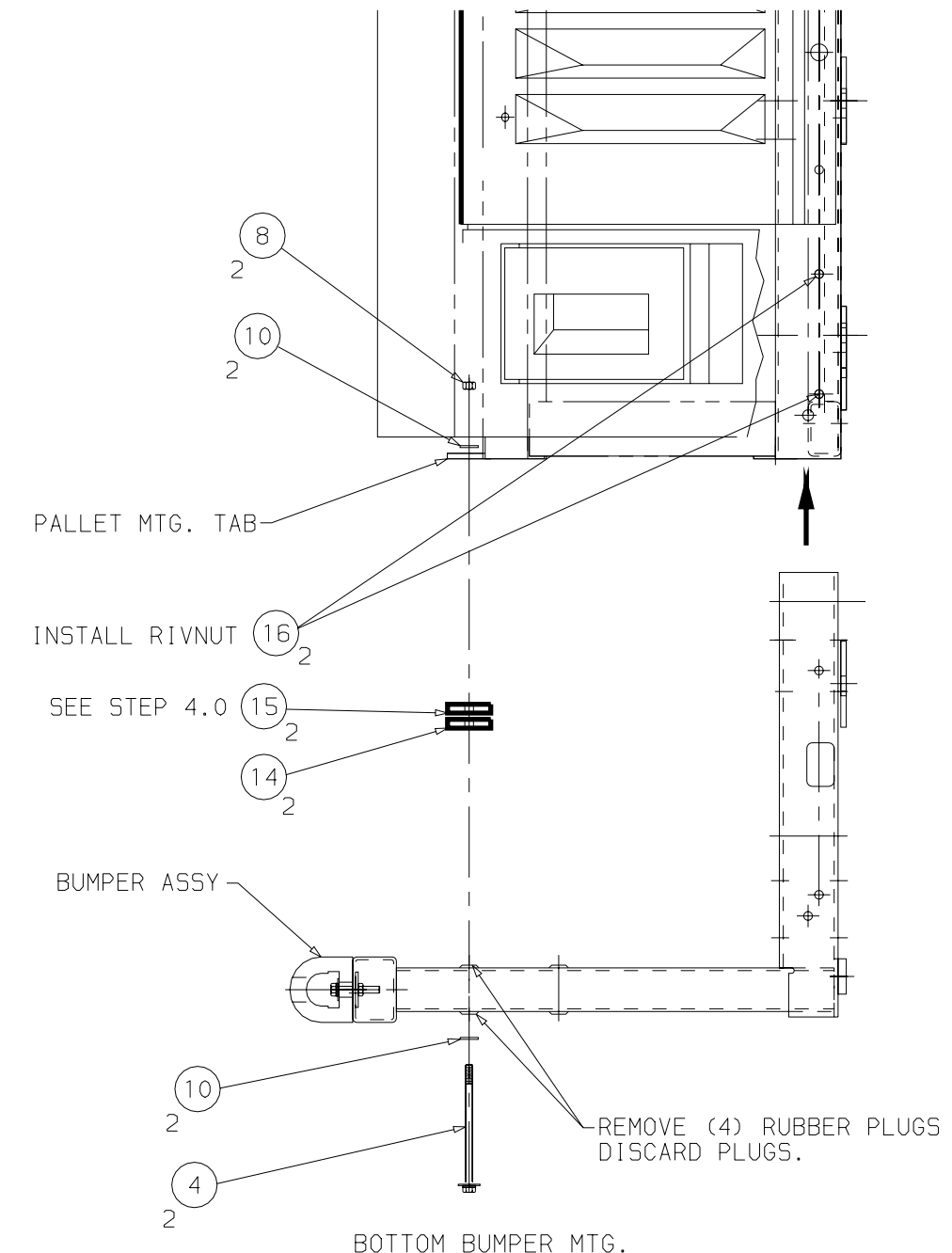
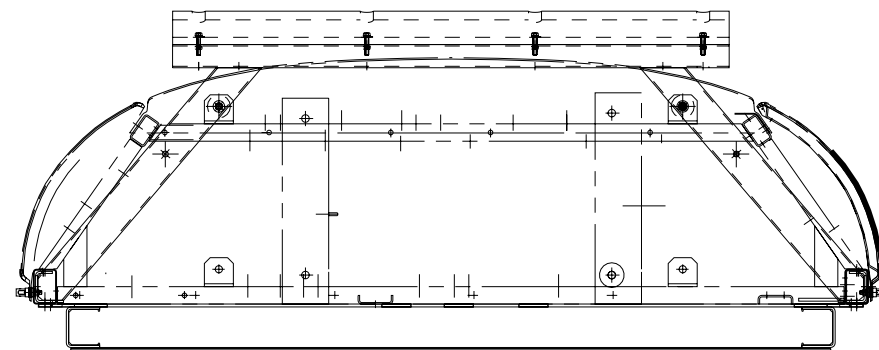
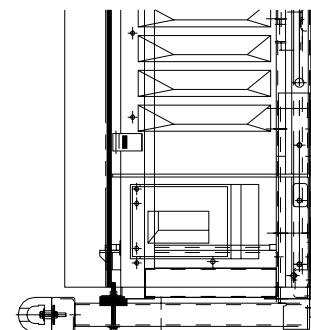
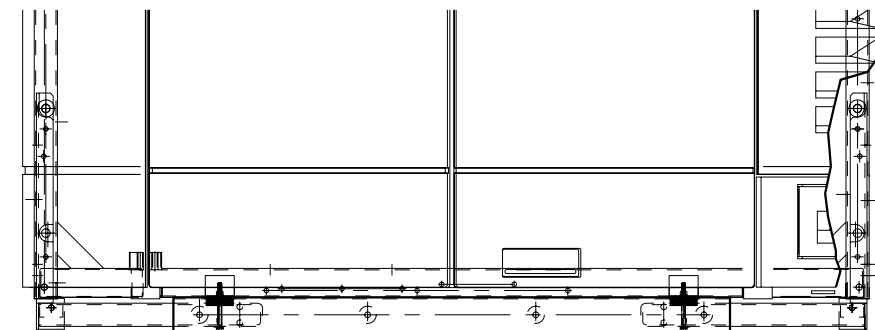

NOTE: IF TRAILER HAS MOUNTING BOLTS PROTRUDING FROM THE FRONT WALL, THEN ALL UNIT PREPARATION AND BUMPER INSTALLATION MUST BE DONE WITH THE UNIT DETACHED FROM THE TRAILER (OTHERWISE THE TRAILER STUDS WILL NOT ALLOW THE BUMPERS TO SLIDE DOWN INSIDE THE UNIT FRAME).

16	34-06051-07	RIVNUT, 1/4-20	2
15	34-01249-21	SPACER	2
14	34-01249-26	SPACER	2
10	34-00366-13	WASHER, PLAIN 3/8	4
8	34-00361-13	NUT, SELF LOCK 3/8-16	2
4	34-00304-28	SCREW, CAP HXHD 3/8-16 X 3.50 LG.	2

ITEM	PART NO.	DESCRIPTION	REQ.
ABOVE ITEMS SUPPLIED WITH KIT P/N.: 76-00524-00			REQ.

SYM	REVISION RECORD	ENGRG.	DATE	APPLICATION ENGRG.	DATE	DRAWN BY	DATE
C	PICTORIALLY UPDATED BUMPER ASSY PER PCA72N226GP07					ZMG	15 MAY 2007
C	PICTORIALLY UPDATED BUMPER ASSY PER PCA72N224GP04.					ZMG	AUG 25, 2004
B	ADDED ITEM 15, CHANGED ITEM 14, -26 WAS -27, MODIFIED INSTALLATION PROCEDURE NOTE 4.0. PER PCA728039G					DLD	09/17/98

SUPERSEDES	TITLE	INSTALLATION INSTRUCTIONS UNIT BUMPER	DRAWING NO. 98-03176 SHEET 3 OF	REV D
------------	-------	--	---------------------------------------	----------