



AN EXCHANGE OF TECHNICAL INFORMATION

Number: TL002 - 2023

Subject: New RG unit 69RG15-120W-24

Released: May 31, 2023

Carrier is releasing a new RG genset unit, 69RG15-120W-24. This unit meets new 2023 California Air Resources Board (CARB) diesel engine emissions requirements for engines in the 8-19KW class. This is achieved by using an engine control unit (ECU) for precise metering and delivery of fuel into the combustion chamber, a high-pressure Common Rail System (CRS) for better atomization via fuel injectors, and a Diesel Oxidation Catalyst (DOC) to convert carbon monoxide and particulates into carbon dioxide and water.

The ECU controls the metering of fuel by activating fuel injectors and adjusting the

suction control valve (SCV) on the high-pressure fuel pump to change the pressure in the CRS. The ECU monitors the pressure with the rail pressure sensor (RPS) and controls it to 10,200-10,800 psi (70-75 MPa) at 1500 RPM, no load. In the event the rail pressure approaches its limit, the pressure limiter (PL) opens and releases fuel back to the tank. The PL is located on the other side of the RPS on the CRS. The fuel is injected three times per cycle: Pre injection uses a small amount of fuel to lower Nitrogen oxides and noise; Main injection uses a higher volume of fuel for combustion; and After injection is used to burn off unburned fuel.

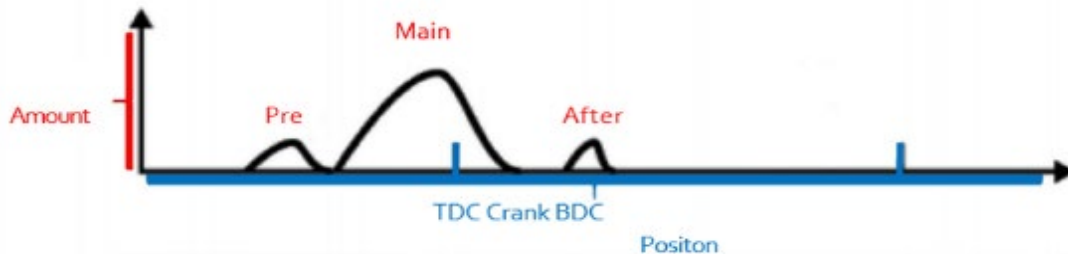
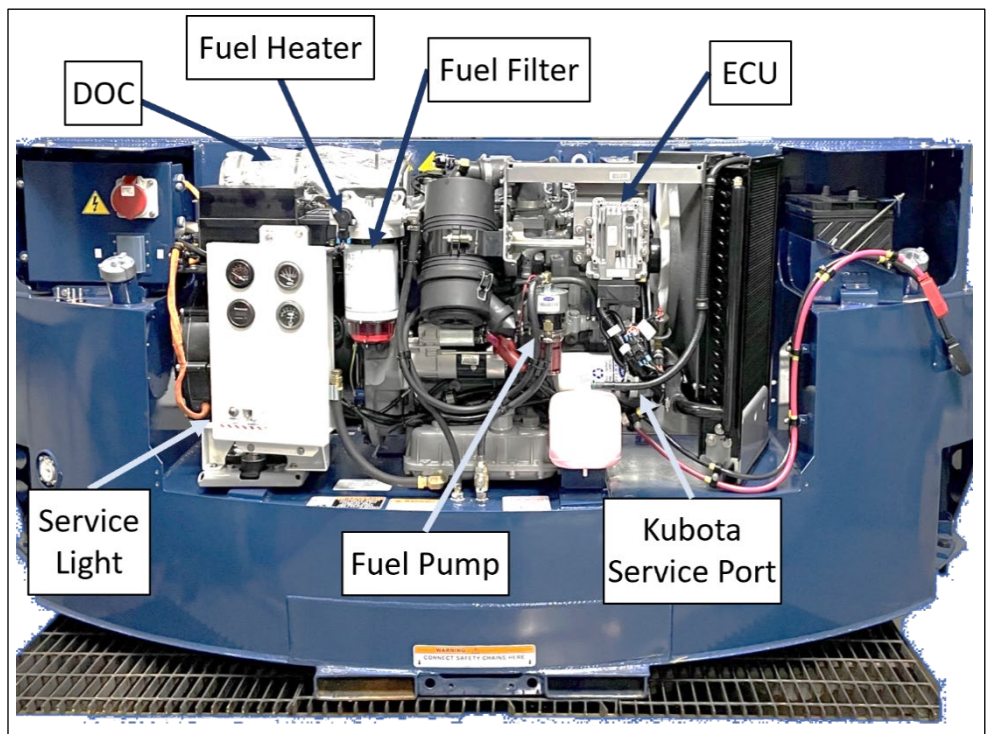

The unit has different control box components compared to previous Carrier gensets. New to the genset is an Engine relay (ENGR), Starter Solenoid relay (SSR), Fuel Pump relay (FPR), Glow Plug relay (GPR), and Service Light. The ENGR closes when the genset is put in the "RUN" position. It provides power to the ECU and connected sensors, the gauge cluster on the control box cover, and the integrated fuel heater. The SSR closes when the run switch is pushed into the "Start" position. The SSR provides power to the starter solenoid to start the engine. The FPR closes when the low oil pressure switch (LOP) closes, after which it powers the fuel pump. The GPR activates if the ECU detects the coolant temperature to be at or below 20°C (68°F) and runs for a set time based on the coolant temperature. When starting the unit, refer to the label on the front of the unit to determine the amount of glow plug time prior to starting the unit. The Service Light is connected to the ECU and will glow whenever the ECU detects an error. The light can be diagnosed via the Kubota Diagmaster Software. The Diagmaster software allows a user to read diagnostic codes, monitor engine data from sensors, and register new injectors. More information regarding installation and use of Diagmaster can be found in the linked material.

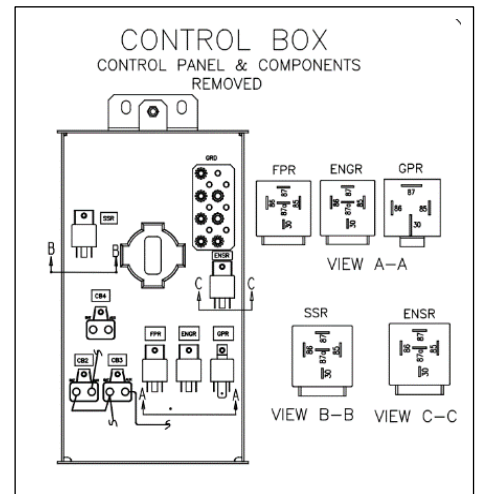

The Service Light is connected to the ECU and will glow whenever the ECU detects an error. The light can be diagnosed via the Kubota Diagmaster Software. The Diagmaster software allows a user to read diagnostic codes, monitor engine data from sensors, and register new injectors. More information regarding installation and use of Diagmaster can be found in the linked material.

Additional sensors on the engine include a crankshaft position sensor (aka Ne sensor in Diagmaster), camshaft position sensor (aka G sensor in Diagmaster), and coolant temperature sensor. The crankshaft position sensor detects the angular position of the crankshaft which the ECU uses to calculate the piston position and RPM of the engine. It is located behind the starter motor. The camshaft position sensor detects the angular position of the camshaft which the ECU also uses to calculate piston position. It is located below the SCV connection. The coolant temperature sensor detects the coolant temperature and sends it to the ECU. It is located near the radiator cap.

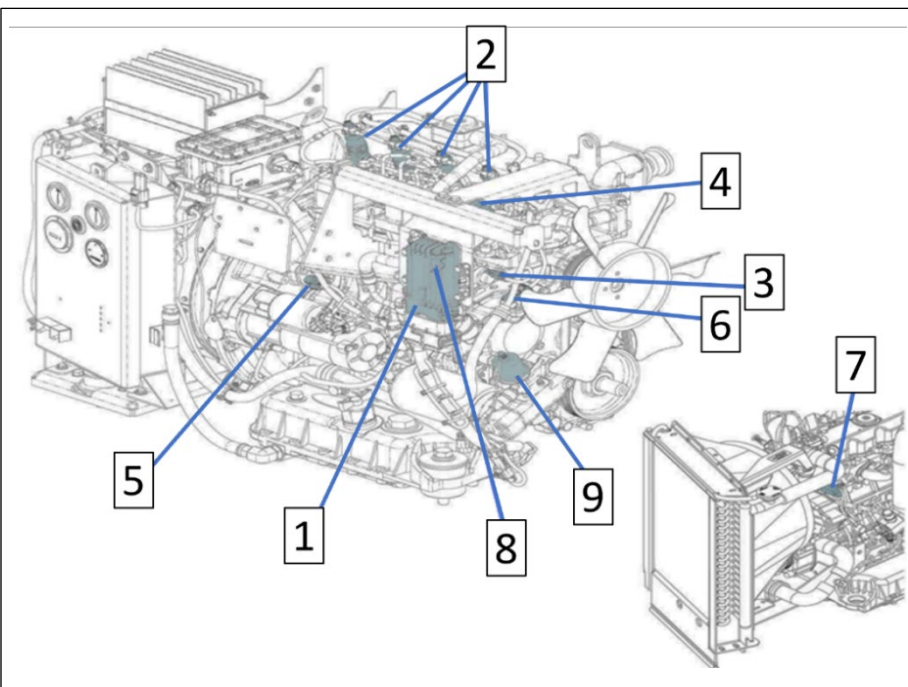

The ECU also tracks the atmospheric pressure, battery voltage, run/stop switch position, and final fuel injection quantity. These values can be seen via Diagmaster and recorded with the data monitor.

- 1) Engine Control Unit (ECU)
- 2) Fuel Injectors
- 3) Suction Control Valve (SCV)
- 4) Rail Pressure Sensor (RPS)
- 5) Crankshaft Position Sensor (Ne sensor)
- 6) Camshaft Position Sensor (G sensor)
- 7) Coolant Temperature Sensor
- 8) Atmospheric Pressure Sensor
- 9) Low Oil Pressure Switch (LOP)

Fuel System Diagram

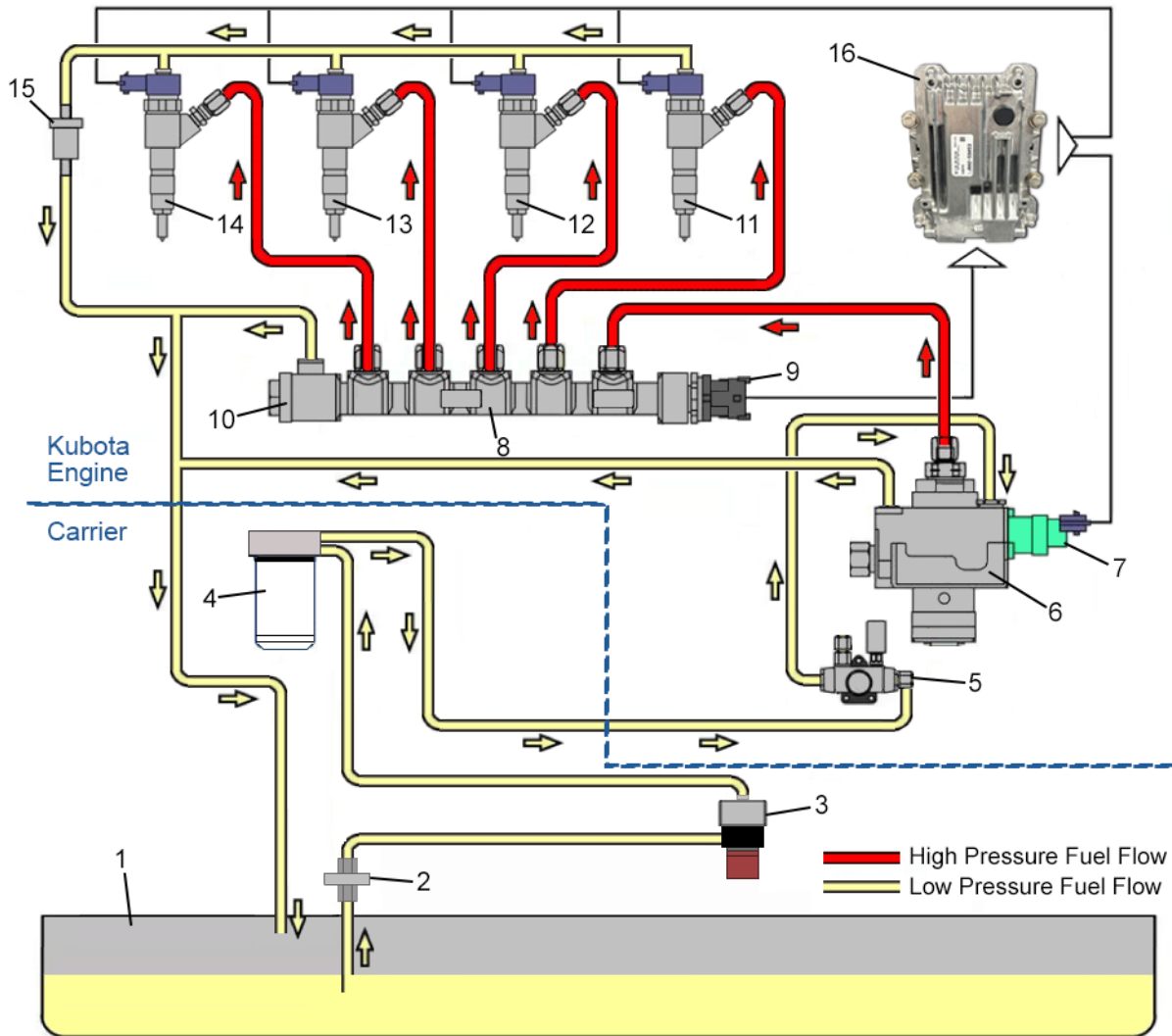

- 1) Fuel Tank
- 2) Fuel Tank Shutoff Valve
- 3) Pre-Filter Pump
- 4) Fuel Filter / Water Separator
- 5) Feed Pump
- 6) High Pressure Supply Pump
- 7) Suction Control Valve (SCV)
- 8) Rail Assembly

- 9) Rail Pressure Sensor (RPS)
- 10) Pressure Limiter (PL)
- 11) Fuel Injector 1
- 12) Fuel Injector 2
- 13) Fuel Injector 3
- 14) Fuel Injector 4
- 15) Check Valve
- 16) Engine Control Unit (ECU)

Startup Instructions:

START

Set Start/Stop switch [ST] on the Refrigeration Unit to position [0]
 Set Generator [CB] to position [0]
 Switch Genset [IGNITION] to [ON] (middle) position to activate glow plugs.

Glow time interval based on ambient temperature.

Ambient Temperature	Duration
68°F / 20°C	4.5 Sec.
50°F / 10°C	8.5 Sec.
32°F / 0°C	9.5 Sec.
14°F / -10°C	15.0 Sec.
-4°F / -20°C	15.0 Sec.
-22°F / -30°C	15.0 Sec.

Once above Pre-start Glow Time interval has been met, hold Genset [IGNITION] switch to start position (up) to start.
 Upon startup of engine, release [IGNITION] switch from start position.
 Set [CB] to position [1] (on).
 Start Refrigeration Unit in accordance with instructions.

STOP

Set IGNITION switch to position OFF.

Common practice would be to allow 15 seconds between setting to ON and initiating the ignition

Engine Data:

Model	V2403-CR-E4B-CTD-3
Fuel	Conventional Ultra Low Sulfur Diesel (ULSD) or ULSD B5 (5% bio component)
Coolant	6 quarts of 50/50 Ethelene Glycol/Water mix
Lubrication	Sump Vol. 15 quarts; API CK-4 or better 0 to 45°F (-18° to 7°C): SAE: 5W30 above 45°F (7°C): SAE: 10W30 or 15W40
Starting Support	Glow plug in combustion chamber Glow plug amperage: Approximately 12 amps at 12 VDC Glow plug resistance (cold): Approximately 1 ohm

Recommended Service Stocking PNs:

- Oil Pressure Switch: 12-00592-16
- Fuel Filter Element: 30-00579-50
- Poly V-Belt: 50-01198-00
- Oil Pressure Sender: 66-U---1--2823-4
- Thermostat Assembly: 25-36203-00
- Oil Pump Assembly: 25-37040-00
- Sensor, Crank Angle: 25-36163-00
- Sensor, Camshaft Angle: 25-39920-00
- Sensor, Coolant Temp: 25-39921-00
- Diagnostic Tool: 07-60198-00

Carb Unit QR Links:

Ops and Service Manual	Service Parts List	Engine Service Parts List
