

CTD PART NUMBER	U.S. ECCN	DESCRIPTION
98-03361-00	EAR99	MUFFLER EXTENSION
98-03361-01	EAR99	MUFFLER EXTENSION

(A)

THESE INSTRUCTIONS ARE TO AID IN THE INSTALLATION OF THE EXHAUST EXTENSION ON X4 AND VECTOR UNITS WITH HORIZONTALLY MOUNTED MUFFLERS.

INSTALLATION PROCEDURE:

1. PERFORM PROPER LOCK OUT TAG OUT PROCEDURE PRIOR TO INSTALLING EXHAUST EXTENSION.
2. INSTALL THE BELLED END OF THE EXHAUST EXTENSION PIPE OVER THE MUFFLER OUTLET.

THE EXHAUST EXTENSION OUTLET MUST BE ORIENTATED IN THE SAME PLANE AS THE MUFFLER OUTLET TO PREVENT RAIN AND SNOW FROM ENTERING THE EXHAUST SYSTEM. FAILURE TO DO SO MAY VOID THE ENGINE WARRANTY.

3. INSTALL MUFFLER CLAMP AND TORQUE TO 17±3 FT-LBS.
4. RUN UNIT AND CHECK FOR LEAKS.

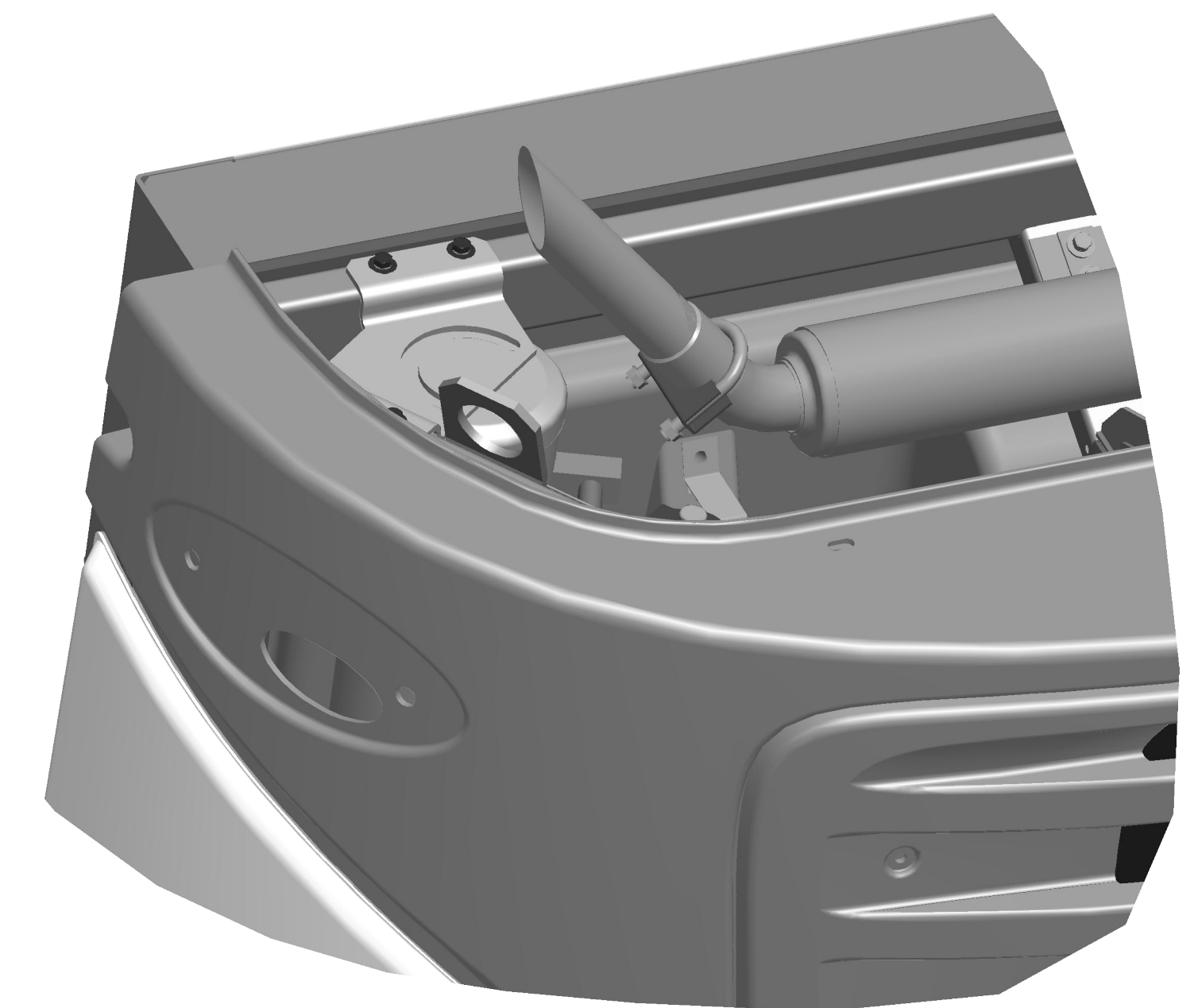
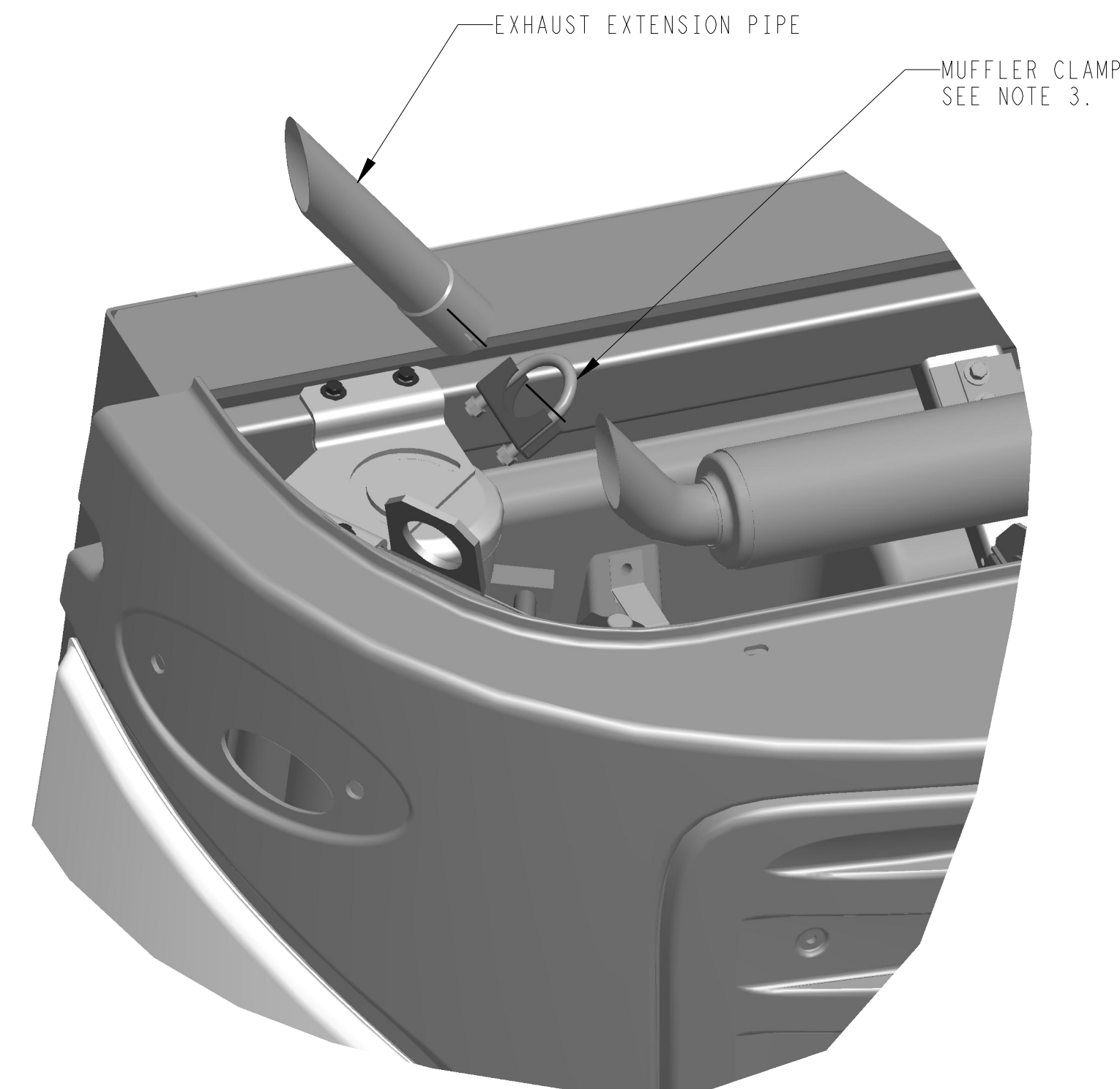

-00

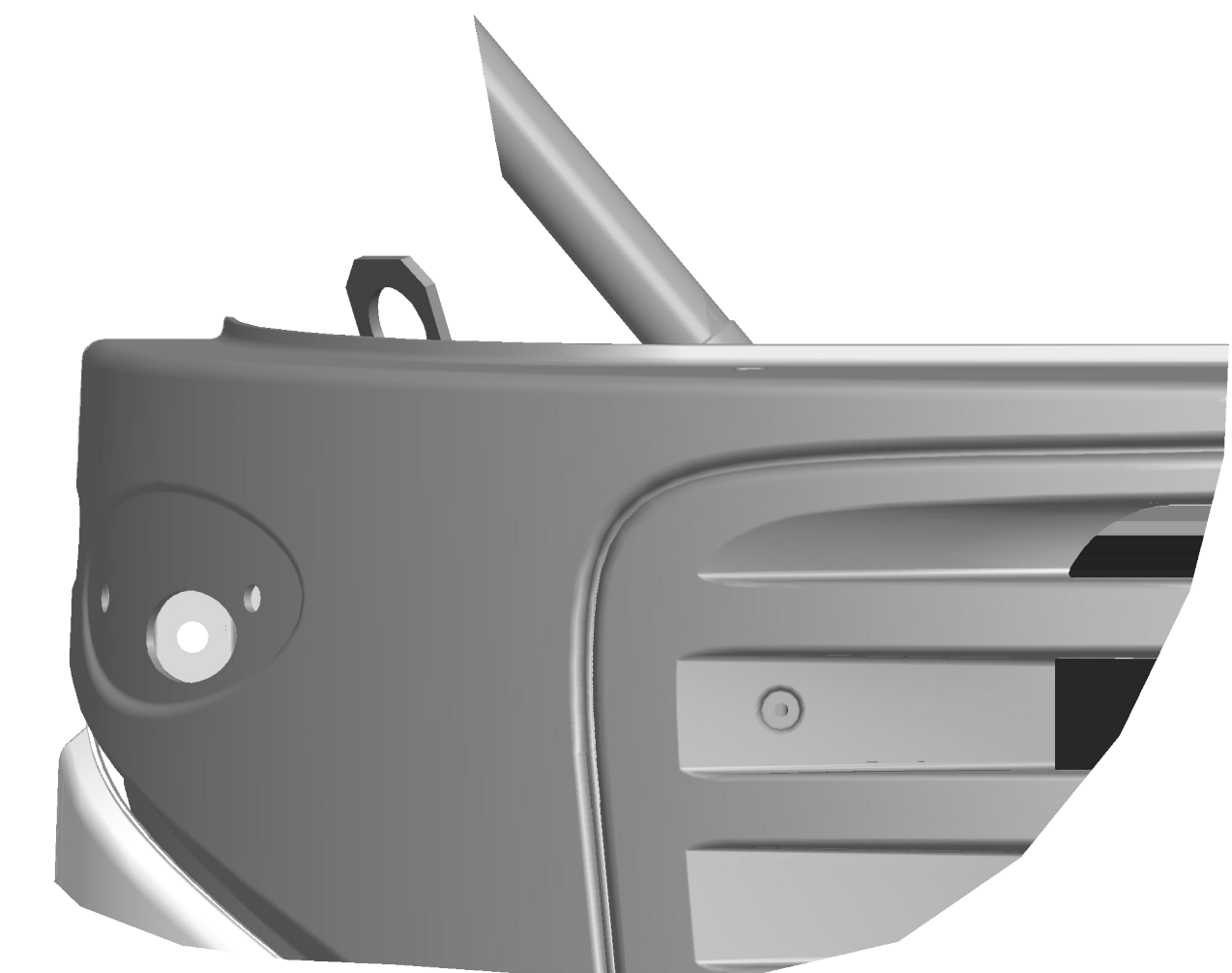
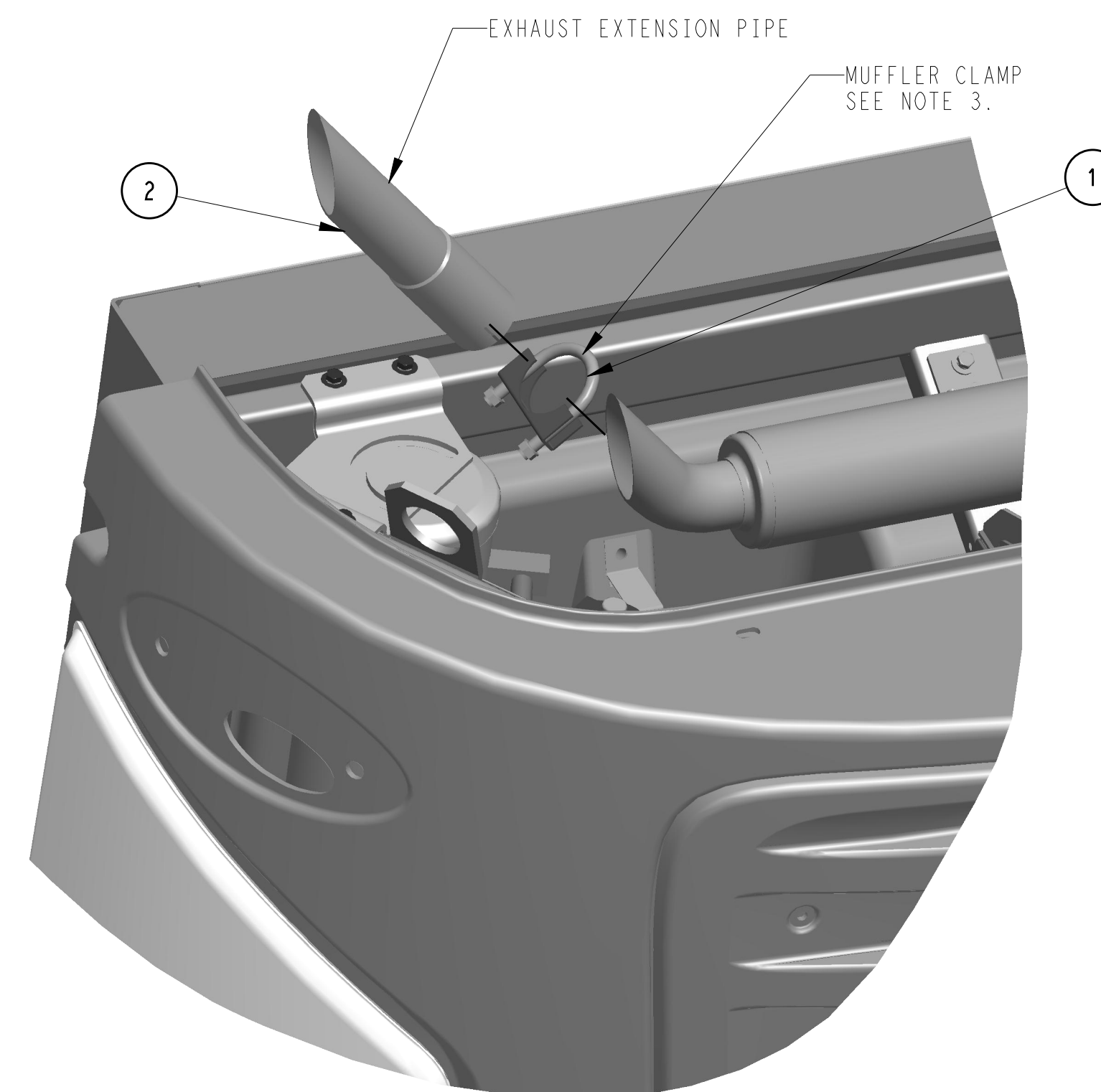

OUTLET ORIENTATION VIEW

-01 (A)

SEE SEPARATE PARTS LIST

SYM	REVISION RECORD	DATE	BY	ENGR.	M.E.	NPCA NO.
A	INITIAL RELEASE OF -01. ADDED CHART.	16 MAY 2018	LT-SK	NH		72N0226P18
-	INITIAL RELEASE.	03 JUN 16	ZMG			72N0308P15

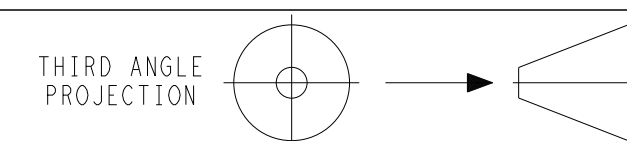

IMPERIAL INCH FORMAT:
UNLESS OTHERWISE SPECIFIED
DIMENSIONS ARE IN INCHES WITH
METRIC CONVERSIONS IN [MILLIMETERS]

TITLE	INSTALLATION INSTRUCTION MUFFLER EXTENSION	DRAWING NO.	98-03361	REV	A
SUPERSEDES:		PART CLASSIFICATION: US SEE CHART		SHEET 1 of 1	

DRAWING CLASSIFICATION: US EAR99