

Bells

Overview

Explosionproof Adaptabels are ideal for use where a distinctive audible signal is required. They feature rugged design with a loud clear sound, and are designed to give trouble free performance for many years. A new concept in bell design has been created to reduce some of the mechanical functions of the conventional bell. A printed circuit board is mounted inside the bell providing an electronic switching for DC versions of the bell, therefore eliminating the need for mechanical contacts.

The bells are vibrating type. They are available in AC or DC models and in 6" and 10" versions.

- **CSA Certified for:**
 - Class I, Division 1, Groups B, C and D,
 - Class II - Division 1, Groups E, F and G, and
 - Class III - Division 1 hazardous locations.

Applications

Explosionproof bells are excellent for timing, scheduling, paging, general alarm and warning for most hazardous locations. Such locations include mines, granaries, flour mills, tankers, refineries and laboratories.

Standard Features

- **Vibrating**
- **Electronic switching**
- **6" and 10" models**
- **AC and DC models**
- **CSA Certified**

Installation and Mounting

The bells mount easily to any type of solid surface using two bolts. This unit is equipped with a sealed, threaded 3/4" fitting and wire leads for connection to the initiating source.

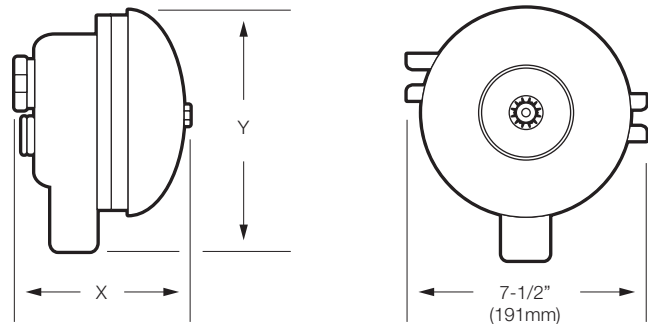

Dimensions	X	Y
6" Bell	4-15/16" (116)	7" (178)
10" Bell	5-1/4" (108)	11-1/8" (282)

Ordering Information

Description	Cat. No.	Size	Volts	RMS Amps	VA	dB at 10' (3M)
A.C. Vibrating	340EX-(*)N5	6" (152mm) 10" (254mm)	120VAC	0.041	2.5	6" = 93 10" = 97
D.C. Vibrating	435EX-(*)G1	6" (152mm) 10" (254mm)	24Vdc	0.240	3.5	6" = 93 10" = 97

(*) Specify size. Example: 340EX-10N5 = 10" 120VAC Bell.

Adaptabel® Explosionproof

340 and 435



Cat. No. 340

