

Application Data

CONTENTS

	PAGE
GENERAL	1
SYSTEM DESIGN CONSIDERATIONS	5
Compressor Ratings	5
Environmental Considerations	5
Code Agency Listings	5
Suction and Discharge Pressure Limits	5
Discharge Temperature Limits	5
06D Thermal Protection	5
06E Thermal Protection	6
Start/Stop Limits	6
Refrigerant Migration and Flooding	6
Suction Piping	6
Discharge Piping	7
Vibration Isolation	7
System Cleanliness and Dehydration	7
LUBRICATION SYSTEM	8
Recommended Oils	8
Oil Pressure Protection	8
Oil Temperature Limits	8
Oil Level	8
Oil Equalization — Parallel Compressors	9
CAPACITY CONTROL	10
Unloaded Operating Guidelines and Limits ...	10
Variable Speed Unloading	10
Cylinder Head Unloading	10
Suction Line PWM Flow Modulation	11
ELECTRICAL DATA	12
Allowable Voltage Range	12
06D Overcurrent Protection	12
06D Electrical Data	13
06E Overcurrent Protection	15
06E Electrical Data	17
RLA for Variable Speed 06D and 06E Compressors	18
06D/E HIGH CONDENSING WITH R-513A	19
COMPRESSOR ACCESSORIES	19
Variable Speed Drives	19
Internal Pressure Relief Valves	19
Suction Inlet Strainer	19

Discharge Mufflers and Baffle Plates	19
Crankcase Heaters	20
Cylinder Head Cooling Fans	20
Liquid Injection	20
Discharge Line Check Valves	20
Compressor Mounts	20
Compressor Service Valves	20

GENERAL

Carlyle 06D and 06E semi-hermetic compressors are ideally suited for commercial refrigeration, air conditioning, process cooling, and environmental chambers. They are extremely flexible and may be used with many of the new refrigerants blends, such as R-448A, R-449A, R-450A, R-452A, and R-513A, in addition to the former refrigerants, such as R-134a, R-404A, R-407A, R407C, R407F, R-507, and R-22. The compressors may be operated at fixed speed on 50 or 60 Hz and are also capable of variable speed operation. The 06D/E compressors are listed with UL (Underwriters' Laboratories) and CSA (Canadian Standards Association) and comply with the low voltage directive of the European Community to carry the CE mark. See Fig. 1 for key features of the 06E compressor. For model nomenclature for 06D and 06E compressors, see Fig. 2 and 3.

High-Efficiency Valve System

The valve system utilizes low lift valves and high flow ports to reduce valve losses, maximize efficiency, and reduce valve stress. Carlyle's valves are made of Swedish steel, the finest material available for this application.

Contoured Pistons and Vented Connecting Rods

The pistons are contoured, allowing the suction valves to mate up with the recess in the pistons, resulting in reduced clearances that increases both capacity and efficiency. The connecting rods are also vented to provide premium bearing lubrication and longer life.

Auto-Reversing High Flow Oil Pump

The positive displacement vane type oil pump is extremely durable and produces a high volume of oil flow in either direction of shaft rotation. The 06D/E oil pump will produce oil pressure quickly, reducing the potential for nuisance oil pressure trips.

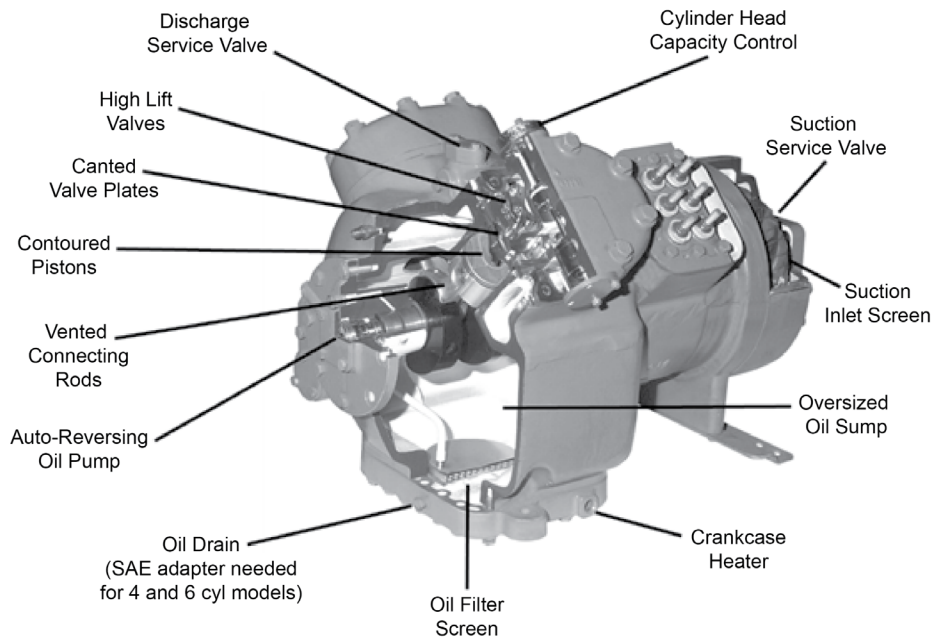

Fig. 1 — Key Features, 06E Semi-Hermetic Reciprocating Compressor

Oversized Oil Sump

On start-up, oil level can temporarily drop too low, causing unnecessary wear in other compressor designs when, on shut-down, the oil is diluted by refrigerant. The oversized oil sump holds extra oil in the crankcase to prevent normal oil migration from dropping the oil level below the safe lubrication range.

High-Efficiency Heavy Duty Motors

These motors have the latest insulation systems, which help to prevent motor burnouts, especially during hot weather periods when operating pressures, temperatures, and currents (amps) are high.

Suction Inlet Screen

The suction inlet screen prevents scale or abrasives from entering the compressor and shortening the life of the motor and compressor.

Oversized Suction Gas Passages

The oversized suction gas passages generate less turbulence, lower pressure drops, and more efficient motor cooling by

suction gas, thereby producing a cooler motor that has a more economical operation and longer life.

Main Bearings — Steel Backed PTFE

Teflon¹ (PTFE) material is used on bearing surfaces to provide greater load carrying ability than other types of materials and is also less susceptible to damage from overheating or liquid refrigerant.

Crankcase Oil Heater

This field-installed accessory warms crankcase oil to reduce refrigerant migration that occurs during shutdown periods.

Capacity Control System

Suction cut-off unloading is an option on all 4 and 6-cylinder Carlyle 06D/E compressors. The compressor capacity can also be modulated with variable speed drives or by pulse width modulation (PWM) control of suction flow.

1. Teflon is a registered trademark of DuPont.

06DR 3 37 0 D A 36 5 A — (RP)*

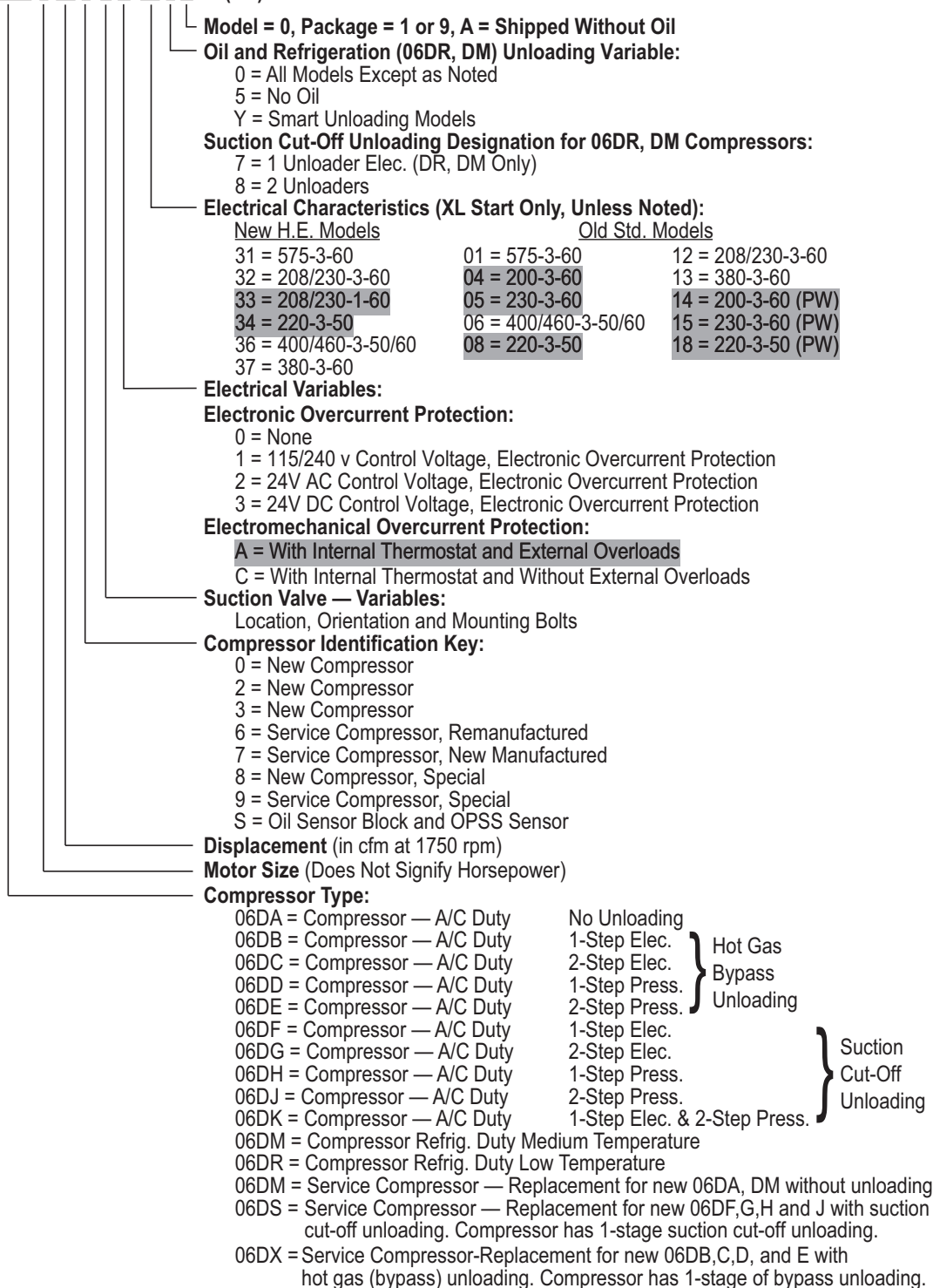

*Refrigeration Partner

Information in shaded area is no longer available in standard factory production

Fig. 2 — 06D Model Nomenclature

06ER 3 99 3 0 A — (RP)*

Model = 0, Package = 1 or 9, A = Shipped Without Oil

Design Variable:

New Compressors

- 0 = OEM Model
- 1 = Carrier A/C Model
- 2 = Old Design Refrigeration Valve Plates
- 6 = Carrier A/C Model
- 9 = Cemak Model
- S = Oil Sensor Block and OPSS Sensor (STD Ctr Head)†
- T = Oil Sensor Block and OPSS Sensor (REV Ctr Head)**

Service Compressors

- 2 = New Manufactured (A/C)
- 4 = Remanufactured (Low Temp.)
- 6 = Remanufactured (A/C)
- 7 = Remanufactured (Med Temp.)

Electrical Characteristics (XL and PW Start, Unless Noted):

- 0 = 208/230-3-60
- 1 = 575-3-60
- 3 = 208/230/460-3-50/60 (460v XL Only)
- 4 = 200-3-60
- 5 = 230-3-60
- 6 = 400/460-3-50/60
- 8 = 230-3-50
- 9 = 220/380-3-60

Displacement (in cfm at 1750 rpm)

Design Configuration

- 0, 1, 2 = Models With Oil
- 3, 4, 5 = Models Without Oil
- 7 = 1 Unloader, Suction Cut-off, Oil-less (ER, EM Only)
- 8 = Special Order
- Y = SMART Unloading Model

Compressor Type:

STD †	REV **			
06EA	06EF	Compressor — A/C Duty	No Unloading	
06EB	06EJ	Compressor — A/C Duty	1-Step Elec.	} Hot Gas Bypass Unloading
06EC	06EK	Compressor — A/C Duty	2-Step Elec.	
06ED	06EL	Compressor — A/C Duty	1-Step Press.	
06EE	06EN	Compressor — A/C Duty	2-Step Press.	} Suction Cut-Off Unloading
06E2	06E6	Compressor — A/C Duty	1-Step Elec.	
06E3	06E7	Compressor — A/C Duty	2-Step Elec.	
06E4	06E8	Compressor — A/C Duty	1-Step Press.	
06E5	06E9	Compressor — A/C Duty	2-Step Press.	
06EM	—	Compressor — Refrig. Duty	Med Temp.	
06ER	—	Compressor — Refrig. Duty	Low Temp.	
06ET	—	Serv. Compressor A/C Duty	Replaces 06E2, 3, 4, 5, 6, 7, 8, and 9	
06EX	—	Serv. Compressor A/C Duty	Replaces 06EA, B, C, D, E, F, J, K, L, and N	
06EY	—	Serv. Compressor Refrig. Duty	Replaces 06ER	
06EZ	—	Serv. Compressor Refrig. Duty	Replaces 06EM	

* Refrigeration Partner

† Standard Center Cylinder Head

** Reversed Center Cylinder Head: service compressors shipped with reverse center head have the letter "R" after the serial number on the shipping box

Information in shaded area is no longer available in standard factory production

Fig. 3 — 06E Model Nomenclature

SYSTEM DESIGN CONSIDERATIONS

Compressors are available for operation in air conditioning as well as low and medium temperature refrigeration application. This guide provides recommendations and requirements for the successful application of the compressors in these applications.

Compressor Ratings

Performance data is available using Carlyle's CARWIN™ performance rating software at www.carwin.carlylecompressor.com. As with all reciprocating compressors, a “run-in” period of 50 to 100 hours may be required to obtain the published performance. Operating envelopes will vary by compressor model and refrigerant. These can be found within the CARWIN rating software.

Environmental Considerations

DESIGN PRESSURES

Table 1 shows the relevant design pressures for the 06D/E compressor applications.

ALLOWABLE AMBIENT TEMPERATURES

All 06D/E compressors have a non-operating (storage, no refrigerant in compressor) temperature range of -40°F to 180°F (-40°C to 82.2°C). These compressors are designed to operate in an ambient temperature range of -25°F to 130°F (-31.7°C to 54.5°C). These are ambient air temperature ranges only; the “Design Pressures” section above defines the pressure limitations that correspond to standstill temperatures.

Code Agency Listings

The 06D/E compressors have both UL and CSA Recognition under the file number SA4936. All UL recognized 06D/E compressors have terminal enclosures that are suitable for outdoor use equipment as a sole enclosure.

Certain models comply with the European Union’s Low Voltage Directive and Machinery Directive. The CE mark is included on the nameplates of those compressors. These models also comply with the UK Electrical Equipment Safety Regulation and

Machinery Safety Regulation. The UKAC mark is included on the nameplates of those compressors.

For the code agency listings to be valid, the compressor may only be applied with refrigerants listed in the Installation Instructions and all requirements listed in those Installation Instructions and this Application Guide must be followed.

Suction and Discharge Pressure Limits

Operating envelopes of the compressor models will differ with each model and refrigerant. These operating envelopes are provided in the CARWIN rating program.

During pulldown, the compressor should not be subjected to low suction pressures for any extended time. Where an extended pulldown period is expected (i.e., large refrigeration systems), the suction pressure must be limited by some positive means.

Discharge Temperature Limits

The actual discharge gas temperature at the compressor discharge service valve must not exceed 275°F (135°C). For hydrofluorocarbon (HFC)/polyolester (POE) applications, the maximum recommended discharge temperature is 250°F (121.1°C). For a given refrigerant, this discharge temperature depends upon the compression ratio as well as the suction return gas temperature.

06D Thermal Protection

06D compressors operating in fixed speed applications with the factory-installed overloads have thermal protection through the triplet positive temperature coefficient (PTC) sensors embedded in the motor windings. For variable speed 06D applications, Carlyle requires that the motor winding thermostat embedded within the windings be connected into the system controls to protect against high motor temperatures when the compressor runs at low speeds for extended periods of time. The internal thermostat trips (opens) at 221°F (105°C) and resets at 181°F (82.8°C). The embedded thermostat has a rated voltage of 277 v and contact rating of 1.6A.

Table 1 — Design Pressures

	COMPRESSOR APPLICATION		SUCTION PRESSURE psia (bar)	DISCHARGE PRESSURE psia (bar)
MAXIMUM OPERATING PRESSURE*	Varies by model and refrigerant		See Operating Envelopes in CARWIN rating program https://carwin.carlylecompressor.com	
MAXIMUM ALLOWABLE PRESSURE†	06D	All refrigerants	104.7 psia (6.2 bar)	417.7 psia (27.8 bar)
	06E		99.7 psia (5.9 bar)	
PROOF TEST PRESSURE**	06D/E		330 psia (22.8 bar)	
LEAK TEST PRESSURE††			240 psia (16.5 bar)	

* Maximum Operating Pressure is the maximum pressure permissible under normal operation.

† Maximum Allowable Pressure is the maximum pressure permissible under atypical circumstances including but not limited to the following:

1. Maximum ambient temperature
2. Setting of any over-pressure relief devices
3. Operating, standby, and shipping conditions
4. System component failure (fan motor, condensing cooling water, etc.)

** Proof Test pressure is the pressure to which the compressor is tested at the factory to validate its integrity.

†† Leak Test Pressure is the pressure to which the compressor is leak tested at the factory.

06E Thermal Protection

All 06EM and 06ER models are supplied with a discharge temperature sensor located in the cylinder head of the compressor. This sensor is designed to open at 295°F, ±5°F (146.1°C, ±2.8°C) and to close at 235°F (112.8°C). The discharge temperature sensor operates as an automatic reset device; however, Carlyle recommends that it is wired into the control scheme in a manner that allows it to function as a manual reset device. The sensor will open on temperature rise and close on temperature fall. The thermostat pilot duty contacts are rated for a 125 sealed va and for an inrush of 1250 va. They are automatically resetting and provide complete thermal protection.

Start/Stop Limits

Compressor start transients are known to place higher stress on the motors and running gear of a compressor. Carlyle has proven a correlation between excessive starts and higher failure rates. Carlyle 06D/E compressors must not start more than 12 times per hour. Carlyle also recommends that the compressors run for at least 5 minutes after each start to aid in proper oil return. In refrigeration racks, well-controlled compressors will generally have no more than 75 starts per day in low temperature racks and 100 starts per day in medium temperature racks. Where feasible, Carlyle recommends adding cycle counters that can be used in system diagnostics and troubleshooting.

Refrigerant Migration and Flooding

Liquid refrigerant, or even excessive amounts of entrained liquid particles in the suction gas, must be kept out of the compressor by proper system design and compressor control. Under running conditions, the presence of liquid refrigerant in the compressor tends to break down the oil film on the cylinder walls, resulting in increased wear to the cylinder walls and piston rings and possible compressor damage. Furthermore, excessive liquid in the cylinders causes hydraulic compression, which can create cylinder pressures as high as 1500 psi (103 bar). This hydraulic loading can cause suction and discharge valve and gasket

failures to occur, while also subjecting the connecting rod, piston, and main bearings to excessive loading. Although laboratory testing of 06D/E compressors has shown that they can withstand substantial flooded starts and floodback, prolonged excessive flooding will eventually cause any compressor to fail.

During compressor “off” cycles, gravity, thermal action, and refrigerant absorption will result in a refrigerant and oil mixture in the compressor crankcase. Gravity flow can be prevented using reverse traps in the piping, but thermal action and the absorption of refrigerant by lubricating oil cannot be eliminated solely by piping design. To minimize the absorption of refrigerant into the oil, Carlyle requires the use of crankcase heaters. It is important, however, never to energize the crankcase heater while the compressor is running, as this may overheat the compressor oil.

Suction Piping

Suction lines and suction risers must be sized to ensure adequate velocity for oil return, taking into account the potential reduction in mass flow associated with changes in operating condition and unloading of the compressors. The lack of proper line sizing may result in premature compressor failure due to oil slugging. Improper suction line sizing can also cause oil loss to the system, causing oil starvation and premature failure of the compressor.

To avoid problems related to refrigerant and/or oil control, piping design is crucial. Carlyle requires suction designs that do not allow free draining of refrigerant or oil into an off compressor. This avoids liquid refrigerant and oil accumulation in off compressors or suction line traps. For that reason, suction manifolds are recommended to be located below their respective compressor inlet locations, as shown in Fig. 4.

Alternately, if the manifolds are located above the inlets, then reverse traps must be installed in each compressor inlet feeder, as shown in Fig. 5. In both situations, each compressor feeder line should include a dip tube into the header that facilitates oil return to each compressor.

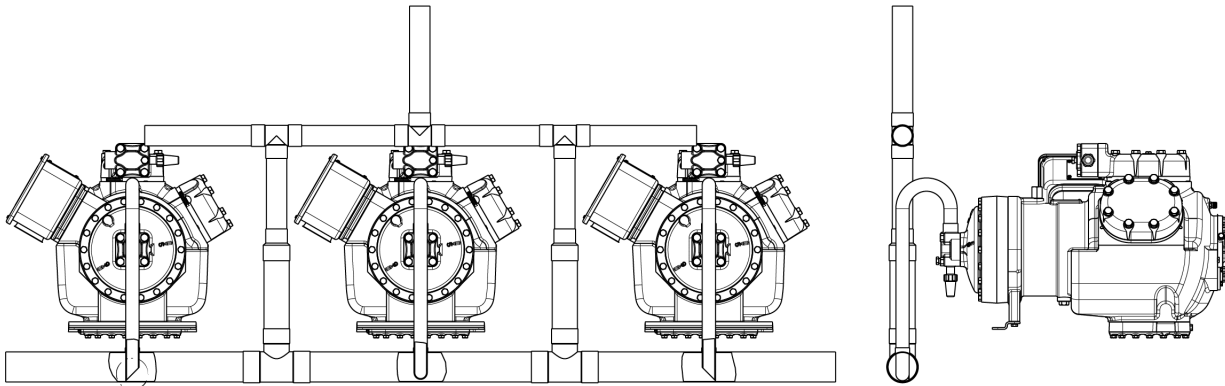

Fig. 4 — Suction Header BELOW Compressors

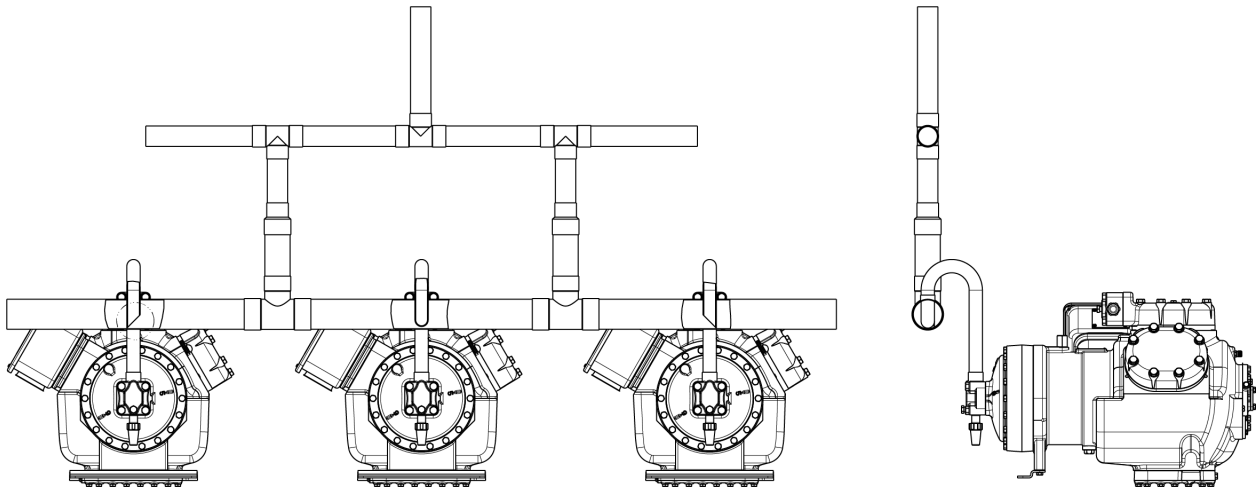

Fig. 5 — Suction Header ABOVE Compressors

The end of these dip tubes should be beveled and configured as shown in Fig. 6. Alternate means for oil return should be reviewed with Carlyle Application Engineering prior to installation.

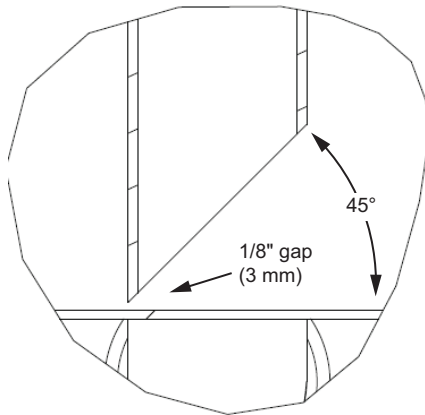

Fig. 6 — Pickup Tube Details

Consult the Carrier System Design Manual (Part 3 — Piping Design) or the ASHRAE Manual — Systems Volume for more details of good system piping practices.

Discharge Piping

Discharge should be piped to avoid logging oil and excessive vibration and protect against leaks from fatigue cracking in the joints. Care should be taken when connecting 2 or more compressors in parallel. It is best to connect each parallel compressor into the branch connection of a “Tee.” Compressor discharge lines should never be setup in a bullhead fashion. (See Fig. 7.)

Consult the Carrier System Design Manual (Part 3 — Piping Design) or the ASHRAE Manual — Systems Volume for more details of good system piping practices.

Vibration Isolation

On installations where noise and vibration must be kept to a minimum, it is desirable to use vibration mounts under the compressor unit, even though the compressors may be spring mounted. Proper precautions must be taken to prevent the transmission of compressor vibration through the piping system. It is also recommended to design the suction line with sufficient “spring” so the suction service valve can be moved aside for access to the suction strainer. Compressors applied in spring-mounted systems should also have adequate flexibility in the suction and discharge piping to avoid the excessive

stresses caused by the start and stop “kick” of the compressor. These excessive stresses can typically be avoided by adding bends in the piping in different directions. Many systems have been designed with compressors mounted to the bases. In these cases, it is important that the compressors be properly torqued to the base or the compressor may produce a “rattle” or transmit excessive vibration to the base.

System Cleanliness and Dehydration

Clean and dry systems are essential for long compressor and motor life and satisfactory operation. Compressor lubricants require special attention; excessive moisture, when combined with heat and refrigerant, can form damaging acids. The recommended limit for moisture is less than 50 ppm for compressors lubricated with mineral oil (MO) or alkylbenzene (AB) lubricants and 100 ppm for POE lubricants.

Liquid line refrigerant filter-driers maintain low moisture content and, in the event of a motor burnout, prevent contamination of the evaporator and other parts of the refrigeration system. Liquid line moisture indicators are recommended in all systems to provide a continuous check on the system’s moisture content.

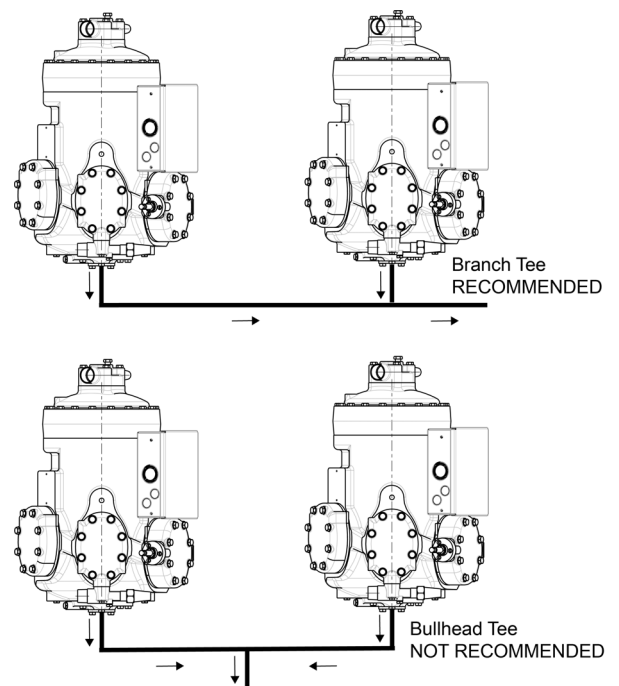

Fig. 7 — Discharge Header Layout

LUBRICATION SYSTEM

Recommended Oils

The 06D/E model compressors are shipped without oil. Table 2 details the Carlyle-approved oils for use in 06D/E applications. All POE oils will readily absorb and retain moisture from ambient air and should be used immediately upon opening the factory sealed container. Note that some of the POE oils shown are not approved for use in any low temperature applications.

Table 2 — Recommended Oils

Manufacturer	Brand Name
For HFC Refrigerants	
Totaline (POE)	P903-1701
Castrol (POE)	E68
ICI Emkarate (POE)	RL68H
Lubrizol Lubrikuhl (POE)	2916S
Texaco Capella (POE)	HFC 68NA
Totaline (POE)	P903-1001*
Castrol (POE)	SW68*
Mobil Arctic (POE)	EAL68*
For HCFC and CFC Refrigerants	
Totaline (MO)	P903-0101
Witco Suniso (MO)	3GS
IGI Petroleum (MO)	Cryol150
Texaco Capella (POE)	WFI32-150
Totaline (AB)	P903-2001
Shrieve Chemicals (AB)	Zerol150

* Do not use in low temperature applications.

LEGEND

AB — Alkybenzene Oil
MO — Mineral Oil
POE — Polyolester-Based Oil

Oil Pressure Protection

Differential oil pressure (oil minus suction pressure) is important to good compressor reliability. Carlyle recommends a 120-second time delay in the oil safety switch. The oil safety switch protects the compressor when lubrication is lost for more than 120 seconds. The switch closes the control circuit at start-up, allowing the compressor to run for 120 seconds. Operating oil pressure must reach the minimum required start pressure above suction pressure within 120 seconds for the switch to remain closed, which allows the compressor to run. If the operating oil pressure falls below the minimum stop pressure above suction for longer than 120 seconds, the switch will open the control circuit, shutting down the compressor. Oil pressure protect devices must be manual reset type.

Use of oil pressure protection is recommended for any fixed speed 06D compressor applications where there is only a single compressor in the circuit. Oil pressure protection is required for any fixed speed 06D compressor applications where more than one compressor operates in parallel with other compressors. Oil pressure protection is required for all 06D variable speed applications and all fixed and variable speed 06E compressor applications, single and parallel compressors.

The 06D/E compressors are available with factory-installed oil pressure protection. (See Fig. 8.) This factory-installed sensor eliminates the need for any field piping connections. The electronic portion of this oil pressure protection is available as a separate accessory for integrating into the system controls.

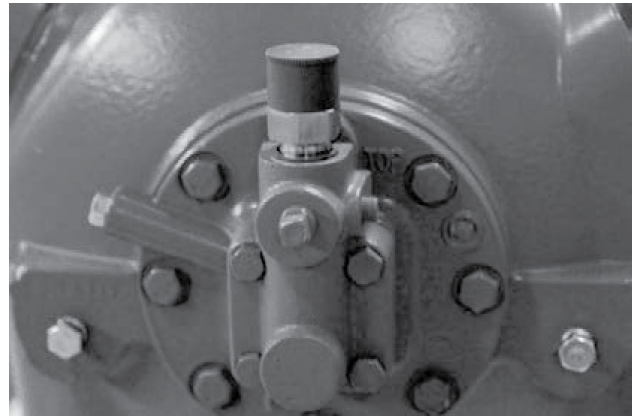

Fig. 8 — Factory-Installed Oil Pressure Protection

Oil Temperature Limits

The oil temperature in the sump must not exceed 160°F (71.1°C).

Oil Level

All refrigeration compressors must have adequate lubrication to ensure trouble-free operation and a long life. When starting up any new system, some oil will be lost to coat the inside of the piping, some will be lodged in low velocity areas of the system, and some will be kept in circulation. This loss must be made up by adding oil to the system after the initial start-up.

Very low compressor oil levels can cause complete loss of lubrication and may result in an immediate compressor failure if not protected against. The loss of oil can also be caused by flooded starts or refrigerant migrating into the oil during an off period and pulling the oil out of its sump during the sudden pressure drop of a start-up. Excessively high oil charges can shorten the compressor life by increasing oil circulation rates, which may result in oil slugging as it returns to the compressor.

Figure 9 shows the minimum and maximum recommended oil levels for the 06D/E compressors. The 06E compressor may have 2 sightglasses that may show different levels during operation. This difference is due to the rotation of the crankshaft.

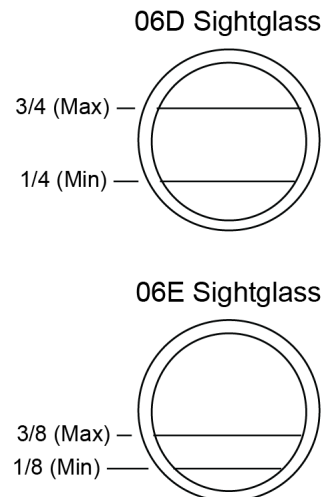

Fig. 9 — Oil Sightglass Level

The oil level should be observed in the sightglass only when the compressor is warmer than the evaporator, either immediately after shutdown or when the crankcase heater has been energized. The level observed when the compressor is not running for a long period may be a mixture of oil and refrigerant, which would not be a true indication of the oil level when the compressor is running.

Oil Equalization — Parallel Compressors

When only two 06D or 06E compressors of the same size are to be connected in parallel, the oil equalization can be accomplished with a single oil equalization line. This line can equalize both oil and gas. This method of equalization is only recommended when there are 2 compressors of the same size and the oil equalization line is less than 4 ft (1.2 m) long. When using a single equalizer line, the compressors must be installed level with one another and the equalizer line must not contain any vertical runs.

The 06E compressors have 2 sightglass connections, either of which may be removed for installation of the equalizer line. A small oil equalization check valve must also be added to those 06E compressors used in parallel. This check valve is part of the 06EA660127 compressor interconnection package and must be installed in the rotor locking bolt (torqued to 13-16 lb-ft, 1.8-2.2 kg-m) of each compressor. (See Fig. 10.) The 06E rotor bolt is accessible by removing the suction strainer from the motor end cover. Installation of the check valve is best accomplished just prior to mounting the suction service valve.

The 06D compressors have only one sightglass, and provision must be made for a sightglass in the oil equalizer line when the 06D compressors are interconnected using an oil equalization line. The 06D oil equalizer interconnection package is 06DA900092. The 06D compressors do not utilize or require the check valve in the rotor lock bolt.

When more than 2 compressors are to be connected in parallel, or if compressors of different displacements are to be connected in parallel, an oil control system utilizing an oil separator, oil reservoir, and floats is recommended. Several manufacturers supply this type of oil management system. It is important that floats are properly selected to control the oil levels as described in the “Oil Level” section on page 8.

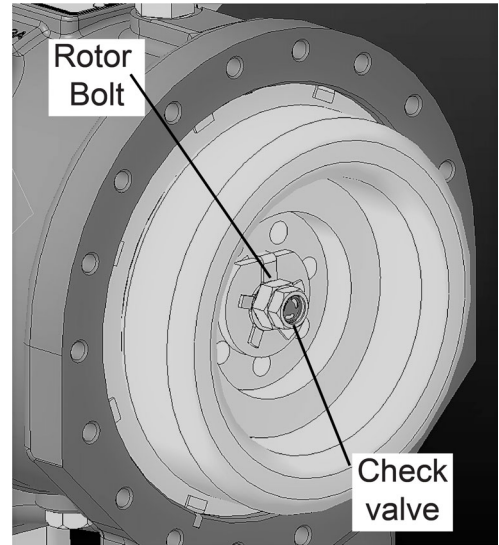
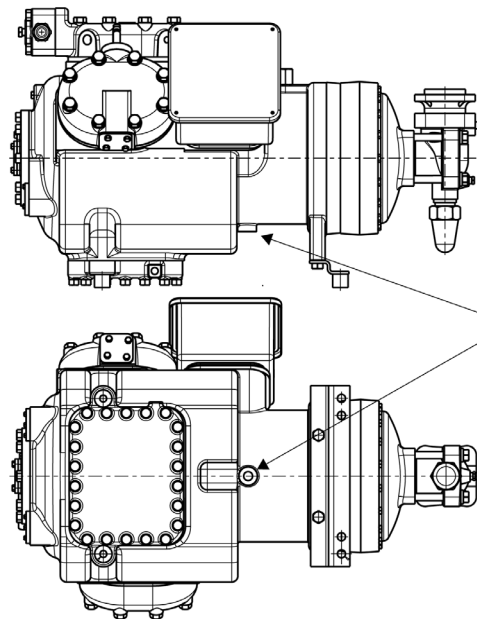

Fig. 10 — Check Valve in 06E Rotor Locking Bolt

Some suction manifold piping arrangements can allow excessive oil to drain into the motor compartment of “off” 06E compressors. To avoid this potential problem, Carlyle recommends the motor barrels of 06E compressors be equalized as shown in Fig. 11 and 12. This motor barrel equalization is recommended in addition to either a float system or an oil compartment equalization line. Motor barrel equalization is recommended for 06E compressors only; the 06D compressors do not have this connection.



Remove existing 5/8-18 SAE oil plug at location indicated. Using same crush washer, reassemble with 5F20-1311 adapter and angle valves to isolate compressors.

Fig. 11 — 06E Motor Barrel Equalization Port

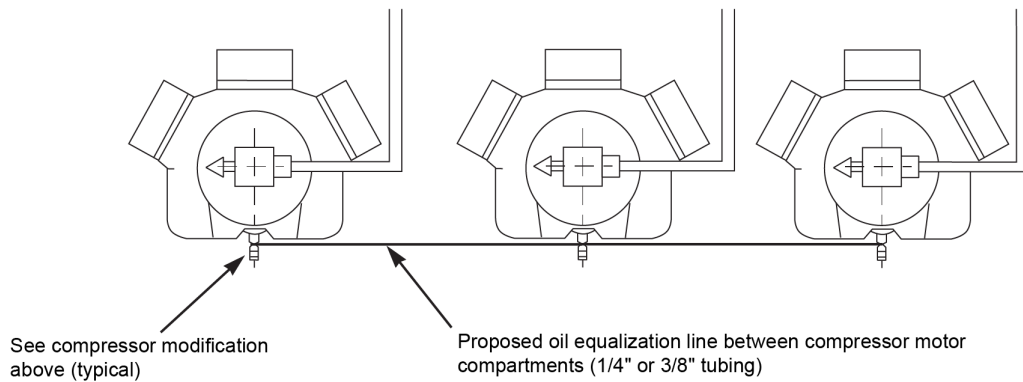

Fig. 12 — 06E Motor Barrel Equalization Line

CAPACITY CONTROL

Unloaded Operating Guidelines and Limits

The ability to return oil back to the compressor is a consideration that the system designer must accommodate from the reduced flow rates when the compressors are unloaded. All system piping, especially the suction line, must consider oil return for both full and part load operation. See the “Refrigerant Migration and Flooding” section on page 6 and the “Suction Piping” section on page 6 for additional piping recommendations.

To increase gas velocities and help return oil to the compressors, Carlyle recommends that the system controls bring the compressor to its nominal flow rate for at least 60 seconds after any 2 hours of continuous unloaded operation. For variable speed systems, this nominal condition means 60 Hz speed. For cylinder head unloading, this means running all cylinders loaded. For suction line flow modulation, this means allowing full uninterrupted flow for 60 seconds. Given the higher risk of oil loss in systems using either variable speed or cylinder head unloading or suction line flow modulation, Carlyle requires the use of oil pressure protection with these unloading systems.

Cylinder head unloading will also result in moderate increases to the discharge gas and motor winding temperatures. As with the piping design, the system design must consider the impact of full and part operation on the discharge and motor winding temperatures. Carlyle recommends that the suction superheat not exceed 25°F (–3.9°C) when the compressors are running in the unloaded state. Discharge temperature limits provided in this guide apply to both loaded and unloaded operation.

Variable Speed Unloading

Carlyle 06D/E compressors are approved for variable speed applications. Conversion of older compressor models may require upgrades to internal hardware. Carlyle Application Engineering should be consulted for any conversion of older compressors to variable speed operation. All compressors applied in variable speed applications must use the factory-installed oil pressure protection switch. The use of alternate oil pressure protection must be approved by Carlyle Application Engineering.

The 06D and 06E compressors are approved for a speed range of 30 to 60 Hz. Consult Carlyle Application Engineering for wider speed range requirements. At the lower end of the speed range, the system design should take care to manage the return gas temperatures to avoid excessive superheat or liquid floodback. Either can adversely affect the oil viscosity, oil pressure, and thus

bearing life. Carlyle recommends that suction superheats be maintained in the range of 10°F to 25°F (5.6K to 13.9K).

Vibration in system components should be carefully evaluated in variable speed systems. The fundamental frequency of the discharge gas pulsations will be 4 times the shaft speed (120-240 Hz) for 4-cylinder compressors and 6 times (180-360Hz) for the 6-cylinder compressors. During the design and/or commissioning phase of a new installation, the entire system must be checked for excessive vibrations with a particular focus on these frequency ranges and multiples thereof. Any system resonance issues that cannot be resolved by clamping must be avoided within the programming of the variable speed drive.

At a constant suction and discharge pressure condition, the current draw of the motor will not change as the shaft speed changes. Motor current draw changes only as the shaft torque changes based on the operating condition.

Cylinder Head Unloading

The cylinder head unloading features on the 06D/E compressors are approved for all refrigerants subject to a few limitations described below. Four-cylinder compressors will unload down to 49 percent of nominal capacity (and mass flow) and will draw 57 percent of nominal power when unloaded to 2 cylinders. Six-cylinder compressors will unload down to 67 percent of nominal capacity (and mass flow) and will draw 71 percent of nominal power when unloaded to 4 cylinders. Six-cylinder compressors in medium and high temperature applications will unload down to 32 percent of nominal capacity (and mass flow) and 46 percent of nominal power when unloaded to 2 cylinders. Consult Carlyle Applications Engineering for applying a second stage of unloading in low temperature applications.

The unloader cylinder head assembly is slightly taller than a plain side cylinder head. These taller cylinder heads result in a slightly wider compressor, approximately 1/2 in. (1.3 cm) wider on 06D models and 3/8 in. (0.95 cm) on 06E models.

The unloader cylinder head may be actuated either by electric solenoid or by an internal pressure actuator. Both electric and pressure-actuated unloading require a minimum system pressure differential in order to actuate the hardware from the unloaded to loaded state. Suction pressures below 30 psig (3.1 bar) require a minimum system pressure differential of 30 psid (2.1 bar). Above 30 psig (3.1 bar), the minimum system pressure differential for the 06D compressor is 40 psid (2.8 bar) and 45 psid (3.1 bar) for the 06E compressors.

ELECTRICALLY ACTUATED UNLOADING

The cylinder head unloader is designed such that the solenoid coils must be energized to unload the compressor. The cylinder head design will automatically unload when the compressor is not running. When the compressor is started and the unloader solenoid coil is de-energized, the compressor will load up as soon as the minimum pressure differentials are met.

Compressors with the electric capacity control may be applied with continuous or automatic pumpdown control. For systems with continuous pumpdown control, Carlyle recommends a minimum of 30 psid (2.1 bar) between the suction pressure cut-in and cut-out points to avoid compressor short cycling.

PRESSURE-ACTUATED UNLOADING

The pressure-actuated cylinder head will automatically unload when the compressor is not running. The pressure actuator has 2 adjustable settings: the control point at which the compressor loads up and a differential setting between this control point and a higher pressure at which the compressor unloads.

The suction pressure at which the cylinder head will load is adjustable from 0 psig to 86 psig (1 bar to 6.9 bar). To set the control point for loading up, turn the adjustment nut clockwise to the bottom stop. In this position, the cylinder load-up pressure is 86 psig (6.9 bar). Then adjust to the desired setting by turning the adjustment nut counterclockwise. Each full turn

counter-clockwise decreases the load-up point by approximately 7.2 psi (0.5 bar). After the control point for loading up is set, the differential setting for unloading the compressor can be set. The set screw should be turned in fully for a 6 psid (0.4 bar) differential setting. This set screw can then be backed out to increase the differential setting. The maximum differential setting is approximately 16 psid (1.1 bar) when the set screw is 10 turns from the backstop. See Fig. 13 for details on these settings. The differential pressure should be set at a high enough value that avoids short cycling of the unloader head.

Compressors with pressure-actuated unloaders should only use single pump-up control schemes. Continuous or automatic pump-down schemes must not be used with pressure-actuated unloaders as this will lead to compressor short cycling.

Suction Line PWM Flow Modulation

Suction line PWM flow modulation allows continuous modulation of the compressor capacity using a solenoid valve installed in the suction line of the compressor. The controller will cycle the valve once every 30 seconds between the open and closed positions. The relative duration of the open versus closed times creates a time average flow rate to the compressor that can be continuously varied. See Carlyle literature 574-078, SMART Pulse Width Modulation Capacity Controller, for more details.

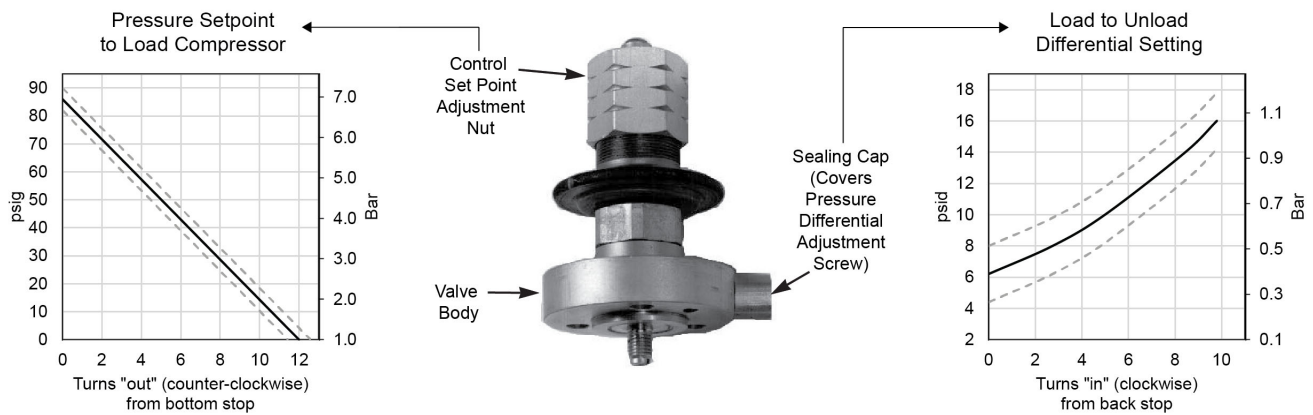

Fig. 13 — Pressure-Actuated Cylinder Head Unloader

ELECTRICAL DATA

Allowable Voltage Range

Table 3 lists allowable voltage ranges for 06D/E compressors.

06D Overcurrent Protection

Fixed speed 06D compressors include a factory-installed electronic overcurrent protection module that interprets a signal from a PTC triplet embedded in the stator windings and a current transformer located in terminal box. This module will shut down the compressor when it is operated at conditions exceeding the

maximum continuous current draw for the compressor or when the winding temperatures exceed their limit.

The electronic overcurrent protection requires that a control voltage be supplied for the compressor protection module. This control voltage is included in the compressor model number. The system designer can select a compressor model with a control voltage of 120/240 vac, or 24 vac or 24 vdc.

The wiring diagrams for the 06D compressors are shown in Fig. 14 (fixed speed), and Fig. 15, (variable speed).

Table 3 — Allowable Voltage Ranges

06D MODELS Digits 11-12	06E MODELS Digit 8	60 Hz			50 Hz		
		NOMINAL	MIN	MAX	NOMINAL	MIN	MAX
12, 32	3	208/230v-3-60 Hz	187v	254v	200v-3-50 Hz	187v	230v
06, 36	3, 6	460v-3-60 Hz	414v	529v	400v-3-50 Hz	342v	460v
01, 31	1	575v-3-60 Hz	518v	661v	—	—	—

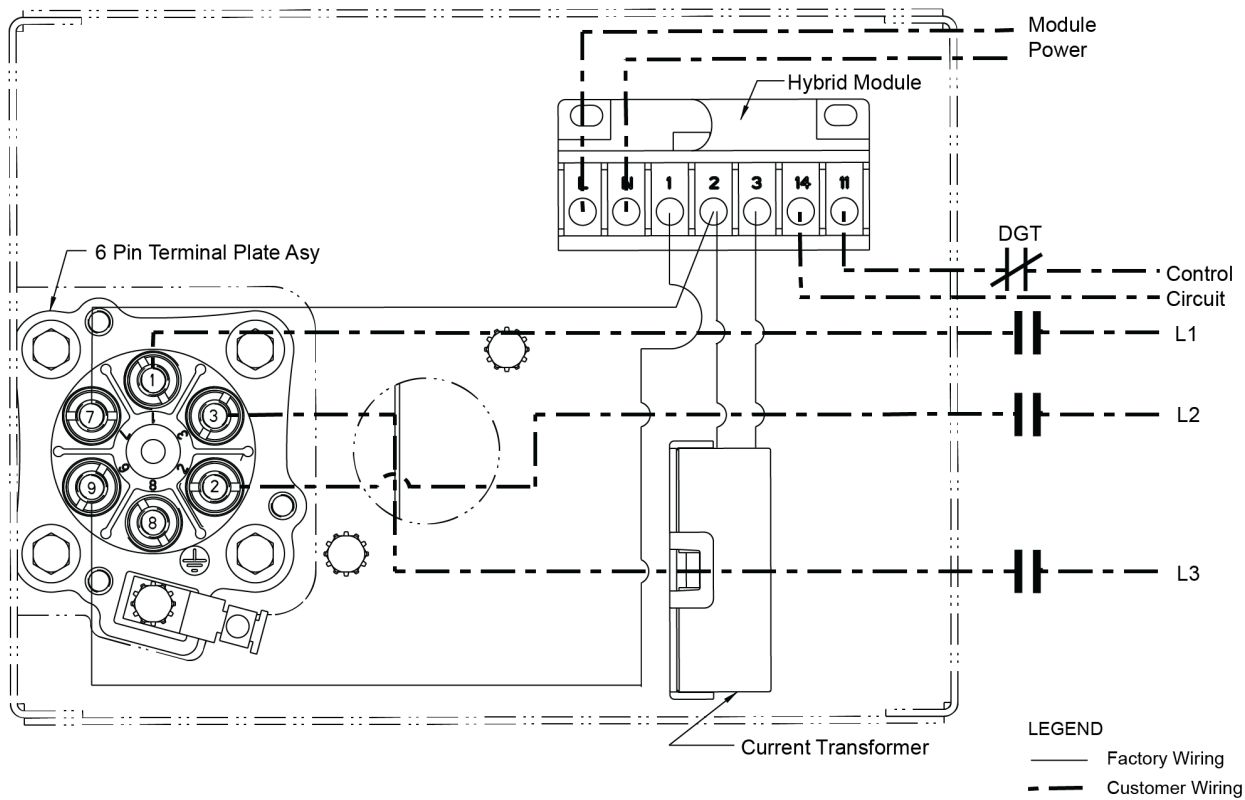

Fig. 14 — 06D Fixed Speed Wiring Diagram

06D, 6-Pin Term Plate
 3-Lead Variable Speed
 460V, 575V, 208/230V

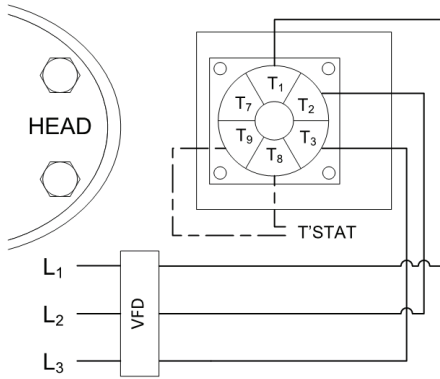

Fig. 15 — 06D Variable Speed Wiring Diagram

The electronic overcurrent protection module is preprogrammed in the factory with the maximum continuous current (MCC) value as listed in the 06D Electrical Data section.

Variable speed 06D compressors may use the overcurrent protection features of the variable speed drive providing that the drive is listed with UL for this purpose. The overcurrent setting of the drive must be consistent with the MCC value as defined in the 06D Electrical Data section.

06D Electrical Data

Table 4 provides locked rotor current for across the line starting and MCC ratings for the 06D compressors. MCC rating is a limitation of the compressor that is independent of both the refrigerant and application range.

For fixed speed applications, the 06D factory-installed overloads are set to trip at this MCC value. Rated Load Amps (RLA) is based on the trip value of the overload device. Because the 06D compressor is considered to be thermally protected, the Rated Load Amps for compressors using these factory-installed overloads will be:

$$RLA = \frac{MCC}{1.56} \left. \vphantom{\frac{MCC}{1.56}} \right\} \text{ For 06D with Factory Overloads}$$

Table 4 — 06D Electrical Data

06DR LOW TEMP COMPRESSORS				VOLTAGE	06DM MED/HIGH TEMP COMPRESSORS			
COMPRESSOR MODEL	HP	MAXIMUM CONTINUOUS CURRENT	ACROSS THE LINE LOCKED ROTOR CURRENT		COMPRESSOR MODEL	HP	MAXIMUM CONTINUOUS CURRENT	ACROSS THE LINE LOCKED ROTOR CURRENT
		(MCC, Amps)	(LRA, Amps)				(MCC, Amps)	(LRA, Amps)
06DR1090G*12†0	2	12.1	53.3	208/230v-3-60Hz 200v-3-50Hz	06DM8080G*12†0	3	17.4	71
06DR013SC*32†0	3	17.4	71		06DM313SC*32†0	5	27	100
06DR316SC*32†0	5	27	100		06DM316SC*32†0	5	27	100
06DR718SD*32†0	5	27	100		06DA818SA*32†0	6.5	44	160
06DR820SD*32†0	6.5	44	160		—	—	—	—
06DR725SD*32†0	6.5	44	160		06DA825SB*32†0	7.5	55.5	198
06DR228SD*32†0	7.5	55.5	198		06DA328SB*32†0	10	62	228
06DR337SD*32†0	10	62	228		06DM337SD*32†0	10	62	228
06DR541SD*12†0	15	89	266		06DA537SB*12†0	15	89	266
06DR1090G*06†0	2	5.5	26.3		—	—	—	—
06DR013SC*36†0	3	8.7	35.5	06DM8080G*06†0	3	8.7	35.5	
06DR316SC*36†0	5	13.5	†0	06DM313SC*36†0	5	13.5	†0	
06DR718SD*36†0	5	13.5	†0	06DM316SC*36†0	5	13.5	†0	
06DR820SD*36†0	6.5	22	80	06DA818SA*36†0	6.5	22	80	
06DR725SD*36†0	6.5	22	80	—	—	—	—	
06DR228SD*36†0	7.5	27.8	99	06DA825SB*36†0	7.5	27.8	99	
06DR337SD*36†0	10	31	114	06DA328SB*36†0	10	31	114	
06DR541SD*06†0	15	40	120	06DM337SD*36†0	10	31	114	
—	—	—	—	06DA537SB*06†0	15	40	120	
06DR013SC*31†0	3	7	28.4	—	—	—	—	
06DR316SC*31†0	5	10.8	40	06DM8080G*01†0	3	7	28.4	
06DR718SD*31†0	5	10.8	40	06DM313SC*31†0	5	10.8	40	
06DR820SD*31†0	6.5	17.6	64	06DM316SC*31†0	5	10.8	40	
06DR725SD*31†0	6.5	17.6	64	06DA818SA*31†0	6.5	17.6	64	
06DR228SD*31†0	7.5	22.2	79	—	—	—	—	
06DR337SD*31†0	10	25	91	06DA825SB*31†0	7.5	22.2	79	
06DR541SD*01†0	15	32	96	06DA328SB*31†0	10	25	91	
—	—	—	—	06DM337SD*31†0	10	25	91	
—	—	—	—	06DA537SB*01†0	15	32	96	
—	—	—	—	—	—	—	—	

* 10th digit of model number (1, 2, or 3) denotes control voltage for electronic overcurrent protection.

† 13th digit of model number denotes with (0) or without (5) factory oil charge.

NOTES:

1. Electrical data for unloading configurations in new compressors 06DF, 06DG, 06DJ, and 06DK have the same electrical data as the non-unloading 06DA model shown in the table.
2. For remanufactured 06D compressors, consult the electrical data from the remanufacturer. For Carlyle remanufactured compressors, the 06DS compressors have the same electrical data as the non-unloading 06DA models shown in the table.

06E Overcurrent Protection

Fixed speed 06E compressors must be applied with properly sized overload relays or calibrated circuit breakers to protect the motor against overcurrent fault conditions. These devices will protect the compressor against running overcurrent, locked rotor, and primary and secondary single phasing.

Some fixed speed 06E models may be configured with a part winding start to reduce inrush current at startup. Carlyle recommends a 1.0 to 1.25 second time delay between energizing the first and second windings.

Variable speed 06E compressors may use the overcurrent protection features of the variable speed drive providing that the drive is listed with UL for this purpose. The overcurrent setting of the drive must be consistent with the (maximum continuous current)

MCC value as defined in the 06E Electrical Data section on page 17.

Overcurrent protection for all 06E compressors must be manually reset.

Wiring diagrams for the 06E compressor are shown in Fig. 16. The different wiring configurations are obtained with different jumper bars and insulators. Fig. 17 shows how these items should be installed on the compressor terminal plate. Jam nut no. 1 is factory installed and should never be in direct contact with the ring terminal. The insulator, ring terminals, and remaining jam nuts must be installed per the installation instructions or there is a risk of damage to the insulation within the terminal plate assembly.

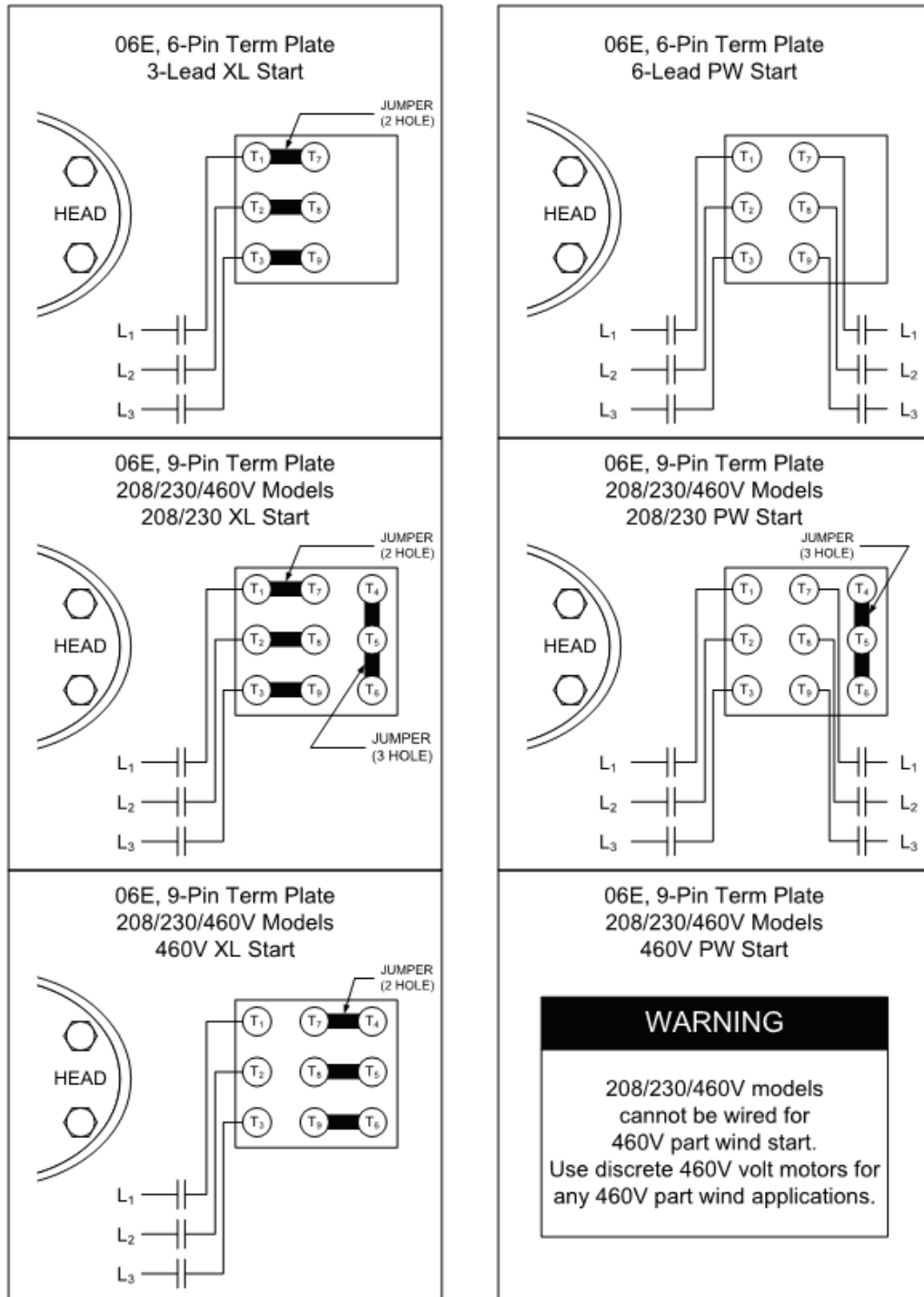
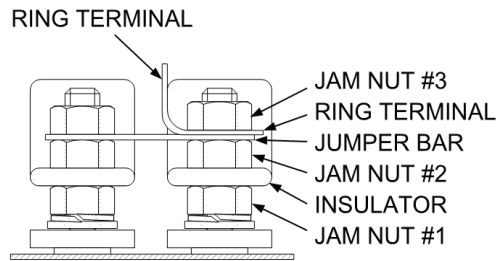

Fig. 16 — 06E Fixed Speed Wiring Diagrams



06E TERMINAL PIN WIRING
DETAILED VIEW

Fig. 17 — 06E Terminal Pin Layout

06E compressors applied with variable speed drives should follow the wiring diagrams in Fig. 18.

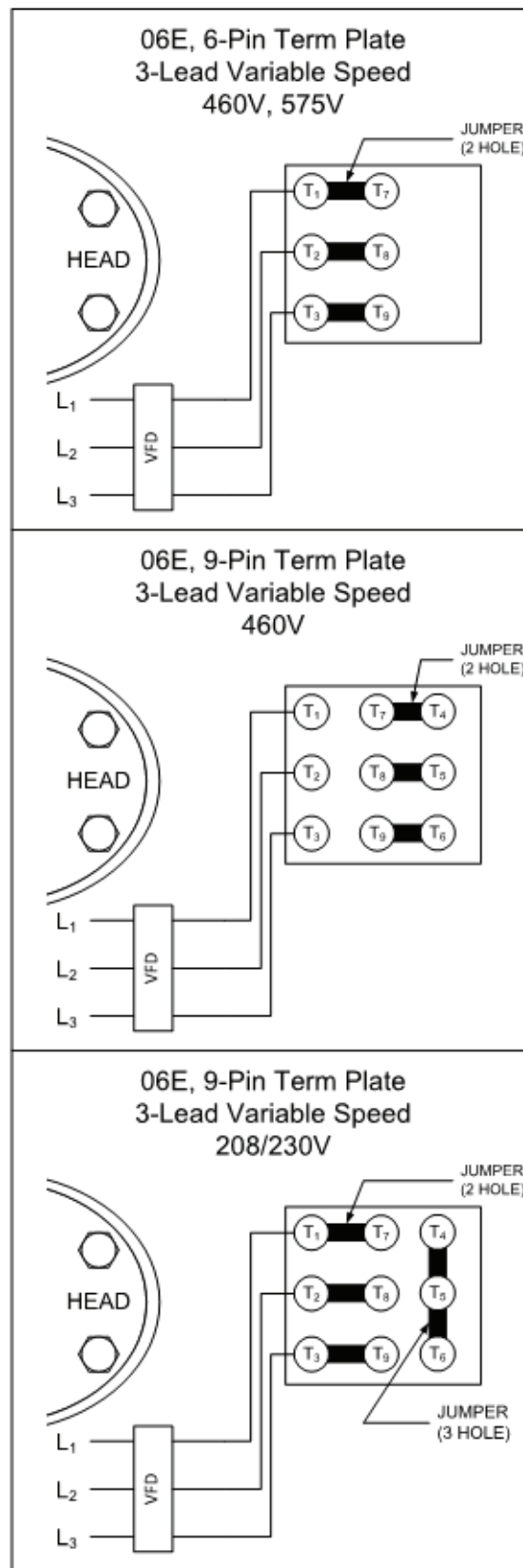

Fig. 18 — 06E Variable Speed Wiring Diagrams

06E Electrical Data

Tables 5-7 provide locked rotor current for across-the-line and part-wind starting and MCC ratings for the 06E compressors. MCC rating is a limitation of the compressor that is independent of

both the refrigerant and application range. The 06E compressors are not provided with factory-installed overloads. The calculation of the Rated Load Amps (RLA) for the 06E compressors will depend on the device that provides this protection.

Table 5 — 06ER Low Temperature Compressor Electrical Data

COMP MODEL	HP	MAXIMUM CONTINUOUS CURRENT	ACROSS THE LINE LOCKED ROTOR CURRENT	PART WIND LOCKED ROTOR CURRENT	VOLTAGE
		(MCC, Amps)	(LRA, Amps)	(LRA PW, Amps)	
06ER*503S0	15	90	283	170	208/230v-3-60Hz 200v-3-50Hz
06ER*653S0	20	108	345	207	
06ER*753S0	20	108	345	207	
06ER*993S0	30	168	506	304	
06ER*503S0	15	46	142	—	460v-3-60Hz 400v-3-50Hz
06ER*506S0				85	
06ER*653S0	20	54	173	—	
06ER*656S0				104	
06ER*753S0	20	54	173	—	
06ER*756S0				104	
06ER*993S0	30	84	253	—	
06ER*996S0				152	
06ER*501S0	15	38	96	59	575v-3-60Hz
06ER*651S0	20	45	120	72	
06ER*751S0	20	45	120	72	
06ER*991S0	30	65	176	106	

See Legend and Notes, page 18.

Table 6 — 06EM Medium Temperature Compressor Electrical Data

COMP MODEL	HP	MAXIMUM CONTINUOUS CURRENT	ACROSS THE LINE LOCKED ROTOR CURRENT	PART WIND LOCKED ROTOR CURRENT	VOLTAGE
		(MCC, Amps)	(LRA, Amps)	(LRA PW, Amps)	
06EM*503S0	15	90	283	170	208/230v-3-60Hz 200v460v-3-50Hz
Use the 06EA*65 model for MT applications					
06EM*753S0	25	140	446	268	
06EM*993S0	35	193	610	366	
06EM*503S0	15	46	142	—	460v-3-60Hz 400v-3-50Hz
06EM*506S0				85	
Use the 06EA*65 model for MT applications					
06EM*753S0	25	70	223	—	
06EM*756S0				134	
06EM*993S0	35	96	305	—	
06EM*996S0				183	
06EM*501S0	15	38	96	59	
Use the 06EA*65 model for MT applications					
06EM*751S0	25	57	164	98	575v-3-60Hz
06EM*991S0	35	77	212	127	

See Legend and Notes, page 18.

Table 7 — 06EA High Temperature Compressor Electrical Data

COMP MODEL	HP	MAXIMUM CONTINUOUS CURRENT	ACROSS THE LINE LOCKED ROTOR CURRENT	PART WIND LOCKED ROTOR CURRENT	VOLTAGE	
		(MCC, Amps)	(LRA, Amps)	(LRA PW, Amps)		
06EA*503S0	20	108	345	207	208/230v200v-3-60Hz 200v-3-50Hz	
06EA*653S0	25	140	446	268		
06EA*753S0	30	168	506	304		
06EA*993S0	40	236	690	414		
06EA*503S0	20	54	173	—	460v-3-60Hz 400v-3-50Hz	
06EA*506S0				104		
06EA*653S0	25	70	223	—		
06EA*656S0				134		
06EA*753S0	30	84	253	—		
06EA*756S0				152		
06EA*993S0	40	118	345	—		
06EA*996S0				207		
06EA*501S0	20	45	120	72		575v-3-60Hz
06EA*651S0	25	57	164	98		
06EA*751S0	30	64	176	106		
06EA*991S0	40	94	276	165		

See Legend and Notes, page 18.

LEGEND AND NOTES, TABLES 5-7

LEGEND

PW — Part Wind

* 5th digit of model number denotes with (3, 4, or 5) or without (0, 1, or 2) factory oil charge.

NOTES:

1. Electrical data for unloading configurations in new compressors 06E2, 06E3, 06E4, 06E5, 06E6, 06E7, 06E8, and 06E9 have the same electrical data as the non-unloading 06EA model shown in the table.
2. For remanufactured 06E compressors, consult the electrical data from the remanufacturer. For Carlyle remanufactured compressors, the 06ET compressors have the same electrical data as the non-unloading 06EA models shown in the table. Similarly, the remanufactured 06EZ will have the same data as the new 06EM models and remanufactured 06EY as the new 06ER.

RLA FOR FIXED SPEED 06E WITH OVERLOAD RELAY

Rated Load Amps (RLA) is based on the trip setting of the overload relay. This trip setting must be set per the manufacturer's instructions and may not exceed the MCC listed for the compressor. The system designer may elect to use a lower trip value, but doing so may impact the overall operating range of the compressor. This can reduce the cost of the electrical system in cases where the full range of the compressor is not required for the system's intended application. In this type of control system, the RLA for the compressor is:

$$RLA = \frac{\text{Trip Setting}}{1.4} \left. \vphantom{\frac{\text{Trip Setting}}{1.4}} \right\} \text{ For 06E with Overload Relays}$$

RLA FOR FIXED SPEED 06E WITH CALIBRATED CIRCUIT BREAKER

With calibrated circuit breakers, the RLA is based on the Must Trip Amps (MTA) rating of the breaker. This MTA value may not exceed the MCC listed for the compressor. The system designer may elect to use a circuit breaker with a lower MTA rating, but doing so may impact the overall operating range of the compressor. This can reduce the cost of the electrical system in cases where the full range of the compressor is not required

for the system's intended application. In this type of control system, the RLA for the compressor is:

$$RLA = \frac{MTA}{1.4} \left. \vphantom{\frac{MTA}{1.4}} \right\} \text{ For 06E with Circuit Breakers}$$

RLA for Variable Speed 06D and 06E Compressors

In variable speed applications, the variable speed drives provide the overcurrent protection for the compressor. The variable speed drive must have the appropriate code agency listings for this purpose. The factory-installed overloads on the 06D compressors must be removed or compressor models purchased without these.

The current trip setting must be set per the drive manufacturer's instructions and may not exceed the MCC listed for the compressor. The system designer may elect to use a lower trip value (and thus smaller drive), but doing so may impact the overall operating range of the compressor. This can reduce the cost of the drive in cases where the full range of the compressor is not required for the system's intended application. In this type of control system, the RLA for the compressor is:

$$RLA = \frac{\text{VFD Trip Setting}}{1.4} \left. \vphantom{\frac{\text{VFD Trip Setting}}{1.4}} \right\} \text{ For Variable Speed 06E}$$

06D/E HIGH CONDENSING WITH R-513A

Carlyle has approved a new operating application for the following 06D and 06E compressor models with R-513A. The following models have been approved for high condensing applications as defined in the blue region of the compressor's operating envelope. (See Fig. 19.) Carwin solution software has been updated to include this new operating envelope and performance data for these specific compressor models. Approved Carlyle compressor models: 06DR820, 06DA818, 06DA825, 06DA328, 06DA537, 06EA550, 06EA565, 06EA575, and 06EA599.

No compressor design changes or modification were required. The standard service parts, electrical motor data, and electrical characteristics for RLA (Rated Load Amps), MCC (Maximum Continuous Current), LRA (Locked Rotor Amps) are defined in our Pocket Service Guide and this application guide and are applicable to the high condensing compressor application.

For high condensing applications above 170°F, the differential pressure between the saturated discharge temperature and saturated suction pressure cannot exceed 385 psig specifically for the 06E model compressors. The 06E compressor has an internal pressure relief valve (PRV) set to lift if the pressure differential between the suction and discharge pressures exceeds 400 psid. If this threshold is exceeded, the PRV will allow discharge gas to bypass to the suction side of the refrigeration system.

COMPRESSOR ACCESSORIES

Variable Speed Drives

Variable frequency drives must not be selected based upon the nominal horsepower of the motor. The variable speed drive must be carefully selected based on the maximum expected current draw of the compressor and the rating factors used by the drive manufacturer.

Internal Pressure Relief Valves

All 06E compressors are equipped with built-in safety relief valves that are factory set to relieve from the discharge to the

suction side of the compressor at a pressure differential of 400 psi (27 bar). On the 4-cylinder 06E compressor, the relief valve is located below the discharge service valve in the compressor crankcase. On the 6-cylinder 06E compressors, it is located in the center bank (below the valve plate) of the crankcase.

Operational problems that result in the compressor operating at elevated head pressures (for example, cycling on the high-pressure switch) may also cause the relief valve to subsequently open at lower operating pressures and thus require replacement.

Internal pressure relief valves are not required in compressors with displacements less than 50 cfm. The 06D compressors do not contain internal pressure relief valves.

Suction Inlet Strainer

Each 06D and 06E compressor is equipped with a suction strainer located in the suction manifold of the motor end bell, except on 2-cylinder models, where it is located on the compressor side of the suction service valve.

Discharge Mufflers and Baffle Plates

Mufflers can reduce discharge gas pulsation and effectively eliminate vibration problems downstream. They should be placed as close to the compressor as possible to maximize efficiency and minimize vibration.

Mufflers should be used on all fixed speed 06D 37 cfm, 06D 41 cfm, and 06E 99 cfm non-unloading compressor models and models with cylinder head unloading above 20 cfm.

Mufflers should be installed per the supplier's direction but are generally able to be mounted in either horizontal or vertical piping runs. When mounted horizontally, care should be taken to ensure that oil does not accumulate within the muffler housing.

Baffle plates may also be used to attenuate discharge gas pulsations. Baffle plates will have higher pressure drops than mufflers for similar levels of performance, but baffle plates can be more easily retrofitted into existing systems. Wherever possible, Carlyle recommends the use of mufflers over baffle plates. Consult the Service Guide, Lit No. 020-611, for guidelines on the selection and use of baffle plates.

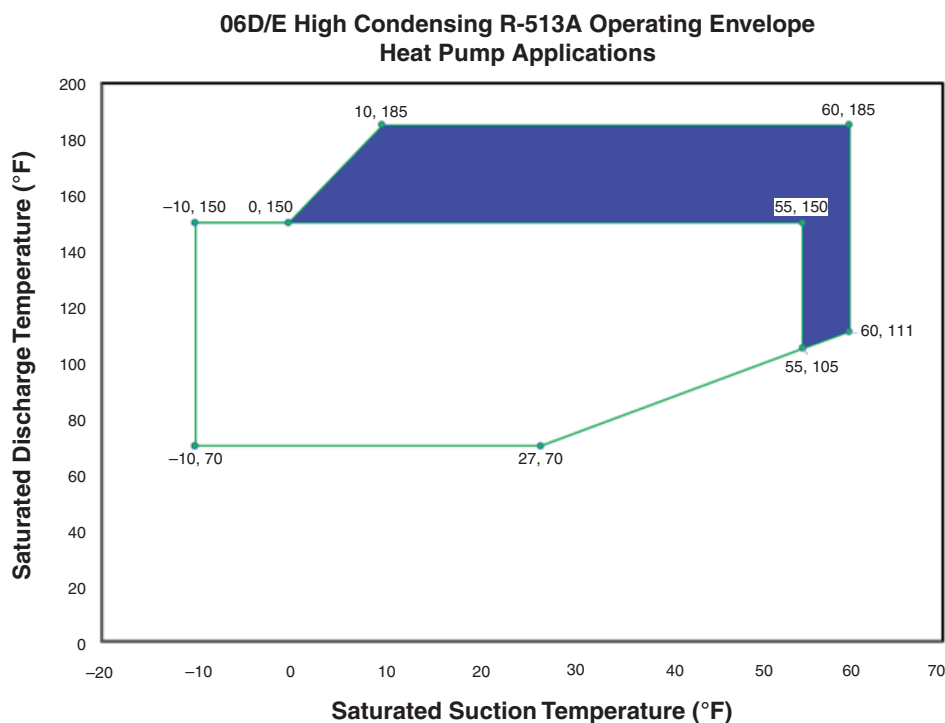

Fig. 19 — 06D/E High Condensing R-513A Operating Envelope Heat Pump Applications

Crankcase Heaters

Carlyle requires the use of crankcase heaters in any application that has access to electrical power when the compressors are not running. The heater should be energized only when the compressor is not operating. For 06D compressors 8-16 cfm, the heater will be bolted onto the bottom cover plate. For all other 06D and 06E compressor models, the heater will be inserted into a blind hole in the bottom cover plate. These heaters should use thermal grease to enhance heat transfer and be constrained such that they do not move out of position during compressor operation.

Cylinder Head Cooling Fans

Cylinder head cooling fans are required in any application where the discharge gas temperature exceeds 250°F (121.1°C). Applications where the compressor is located in an airstream with a consistent velocity of 8 to 10 fps (~3 m/s) do not require cylinder head fans.

Liquid Injection

Liquid refrigerant injection may be needed in some applications to keep discharge temperatures under the required limit in some high pressure ratio low temperature operating conditions. Liquid injection will reduce compressor capacity and can lead to

increased risks of wear in the cylinders and running gear of the compressor. System controls towards lower suction gas superheats and lower operating pressure ratios are preferred in controlling discharge gas temperatures. Consult Application Engineering prior to installing liquid refrigerant injection on the Carlyle 06D or 06E compressors.

Discharge Line Check Valves

Under certain conditions, a discharge line check valve is a valuable means for preventing condensed refrigerant from migrating into the cylinder heads of an idle compressor.

Compressor Mounts

The 06D and 06E compressors may use either rigid mounts or spring mounts. Variable speed applications using spring mounts should be carefully evaluated to ensure that there are no resonances across the entire speed range.

Compressor Service Valves

Recommendations for suction and discharge service valves for fixed speed applications can be found in Table 8. For variable speed applications, Carlyle recommends choosing the largest valve, standard or alternate, that is identified for the compressor model.

Table 8 — Service Valves

COMPRESSOR MODEL	SUCTION SERVICE VALVE				DISCHARGE SERVICE VALVE									
	RECOMMENDED		ALTERNATE		RECOMMENDED		ALTERNATE							
06DM808	7/8" ODF	06DA660061	5/8" ODF	06DA660060	5/8" ODF	06DA660060	7/8" ODF	06DA660061						
06DM313	1-1/8" ODF	06DA660064	7/8" ODF	06DA660061										
06DM316			7/8" ODF	06DA660062					7/8" ODF	06DA660061	5/8" ODF	06DA660060		
06D*818	1-3/8" ODF	06DA660065	1-5/8" ODF	06EA660090	1-1/8" ODF	06DA660064	7/8" ODF	06DA660062						
06D*825			1-1/8" ODF	06DA660063										
06D*328			1-5/8" ODF	06DA660065					1-1/8" ODF	06DA660063				
06DM337	1-5/8" ODF	06EA660090	1-5/8" ODF	06DA660065	5/8" ODF	06DA660060	7/8" ODF	06DA660061						
06D*537			1-1/8" ODF	06DA660063										
06DR109	7/8" ODF	06DA660061	5/8" ODF	06DA660060	7/8" ODF	06DA660060	7/8" ODF	06DA660061						
06DR013	1-1/8" ODF	06DA660064	7/8" ODF	06DA660062										
06DR316			1-3/8" ODF	06DA660065					1-5/8" ODF	06EA660090	5/8" ODF	06DA660060		
06DR718	1-3/8" ODF	06DA660065	1-5/8" ODF	06EA660090	7/8" ODF	06DA660061	5/8" ODF	06DA660060						
06DR820			1-1/8" ODF	06DA660063										
06DR725			7/8" ODF	06DA660062					1-1/8" ODF	06DA660064				
06DR228	1-5/8" ODF	06EA660090	1-3/8" ODF	06DA660065	1-1/8" ODF	06DA660064	7/8" ODF	06DA660062						
06DR337									1-3/8" ODF	06DA660065	1-5/8" ODF	06EA660090	1-1/8" ODF	06DA660063
06DR541									1-1/8" ODF	06DA660064	7/8" ODF	06DA660062		
06EA†50	2-1/8" ODF	06EA660164	No alternate	No alternate	1-3/8" ODF	06DA660064	1-5/8" ODF	06EA660090						
06EA†65					1-1/8" ODF	06DA660063	1-3/8" ODF	06DA660065	1-1/8" ODF	06DA660063				
06EA†75					1-5/8" ODF	06EA660090	1-3/8" ODF	06DA660065	1-1/8" ODF	06DA660063				
06EA†99	1-1/8" ODF	06DA660064	7/8" ODF	06DA660062	1-3/8" ODF	06EA660090	1-3/8" ODF	06DA660065						
06EM†50									1-1/8" ODF	06DA660064	7/8" ODF	06DA660062		
06EM†75									1-3/8" ODF	06DA660065	1-5/8" ODF	06EA660090	1-1/8" ODF	06DA660063
06EM†99	1-5/8" ODF	06EA660090	7/8" ODF	06DA660062	1-1/8" ODF	06DA660064	7/8" ODF	06DA660062						
06ER†50									1-1/8" ODF	06DA660064	7/8" ODF	06DA660062		
06ER†65									1-3/8" ODF	06DA660065	1-5/8" ODF	06EA660090	1-1/8" ODF	06DA660063
06ER†75	1-3/8" ODF	06DA660065	7/8" ODF	06DA660062	1-5/8" ODF	06EA660090	1-1/8" ODF	06DA660063						
06ER†99									1-1/8" ODF	06DA660064	7/8" ODF	06DA660062		
All Models Installed in PWM Applications	1-5/8" ODF	06EA660090	1-1/8" ODF 1-3/8" ODF	06DA660063 06DA660065	—									

* 06D models, 4th digit of model number (A, F, G, H, J, or K) denotes high temperature models.

† 06E models, 5th digit of model number denotes with (0, 1, or 2) or without (3, 4, or 5) factory oil charge.