

SPARE PARTS CATALOG

OFFICE PRO 60



MOVINCOOL®
THE #1 SPOT COOLING SOLUTION

Table of Contents

No.	UNIT PART NUMBER	PRODUCTION PERIOD	REFRIGERANT	SECTION	ISSUE DATE (mm/yy)
1	GX484000-3690	FROM April 2007 (0407) TO Present	R410A	SP0010-01 Page 3 ~ 13	04/08
2	LA484000-2500	FROM May 2001 (0501) TO March 2007 (0307)	R22	SP0009-01 Page 15 ~ 25	04/08

© 2008 DENSO SALES CALIFORNIA, INC.

All rights reserved. This book may not be reproduced or copied, in whole or in part, without the written permission of the publisher. DENSO SALES CALIFORNIA, INC. reserves the right to make changes without prior notice. MovinCool is a registered trademark of DENSO Corporation.

OFFICE PRO 60

Unit Part No: GX484000-3690

Production Period: From April 2007 (0407)
To Present

OFFICE PRO 60

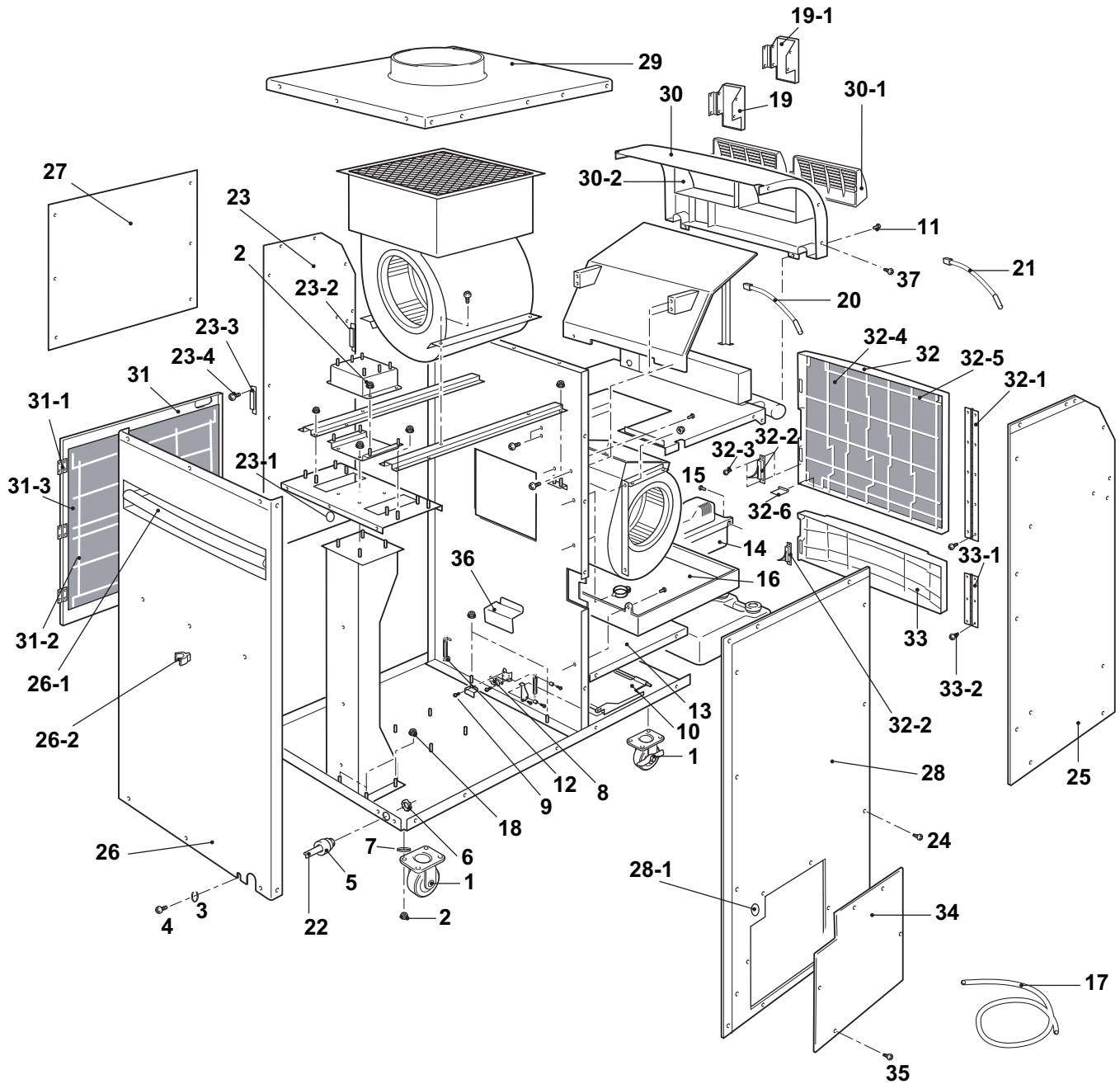

OFFICE PRO 60

ILL. NO.	DESCRIPTION	PART NO.	QTY.	MODIFICATION DATE (mm/yy)	REMARKS
1	Caster w/Brake	LA484702-0350	4		
2	Nut	LA480929-0140	16		M10×1.5
3	Washer, Plate	90201-06400	1		Ground
4	Screw	90051-06120	1		Ground (M6×1, L=12)
5	Connector (Retainer, Power Cord)	LA484784-002A	1		
6	Nut, Holder (Retainer, Power Cord)	LA484919-0090	1		
7	Plate	LA484311-2440	16		
8	Switch, Drain Tank	LA484502-0380	1		For Drain Tank
9	Screw w/Washer	91310-03161	2		M3×0.5, L=16
10	Frame Assy	LA484300-1650	1		
11	Screw	949006-5850	34		M4×0.7, L=10
12	Clip	484917-0280	2		
13	Frame Assy	LA484300-1662	1		
14	Pump Assy	GX484780-0220	1		
15	Screw w/Washer	91370-04101	2		M4×0.7, L=10
16	Pan Assy, Drain	GX484430-0610	1		Drain Pan
17	Hose, Drain	LA484432-018B	1		
18	Nut	949056-1430	17		M6×1
19	Switch Assy	GX484560-1812	1		Operation Panel & PCB w/ILL.NO.19-1
19-1	Cover Assy	GX484420-0510	1		Operation Panel
20	Thermistor, Room Temperature	LAY84532-0021	1		
21	Thermistor, Anti-Freeze Up	LA484532-0041	1		
22	Wire Assy, Power Cord	LA484930-634C	1		
23	Panel Assy, Right Front	GX484410-8190	1		w/ILL.NO.23-1~23-4
23-1	Grommet	LA484926-0500	1		
23-2	Catch	LA481922-0030	3		
23-3	Holder (Magnet Type)	484927-0990	2		
23-4	Screw	949006-4440	4		M3×0.5, L=8
24	Bolt	LA480919-0290	69		M6×1, L=10
25	Panel Assy, Left Front	GX484410-8200	1		
26	Panel Assy, Rear	GX484410-8210	1		w/ILL.NO.26-1~26-2
26-1	Handle	LA484451-0080	1		
26-2	Clip	LA484917-042A	2		For Power Cord
27	Panel Assy, Right Top Rear	GX484410-8220	1		
28	Panel Assy, Left Rear	GX484410-8230	1		w/ILL.NO.28-1
28-1	Grommet	GX484926-0700	1		
29	Panel Assy, Top	GX484410-8240	1		
30	Panel Assy, Top Front	LA484410-6021	1		w/ILL.NO.30-1~30-2
30-1	Air Louver, Outlet	LA480431-0101	2		
30-2	Pin	LA484913-0070	6		

OFFICE PRO 60

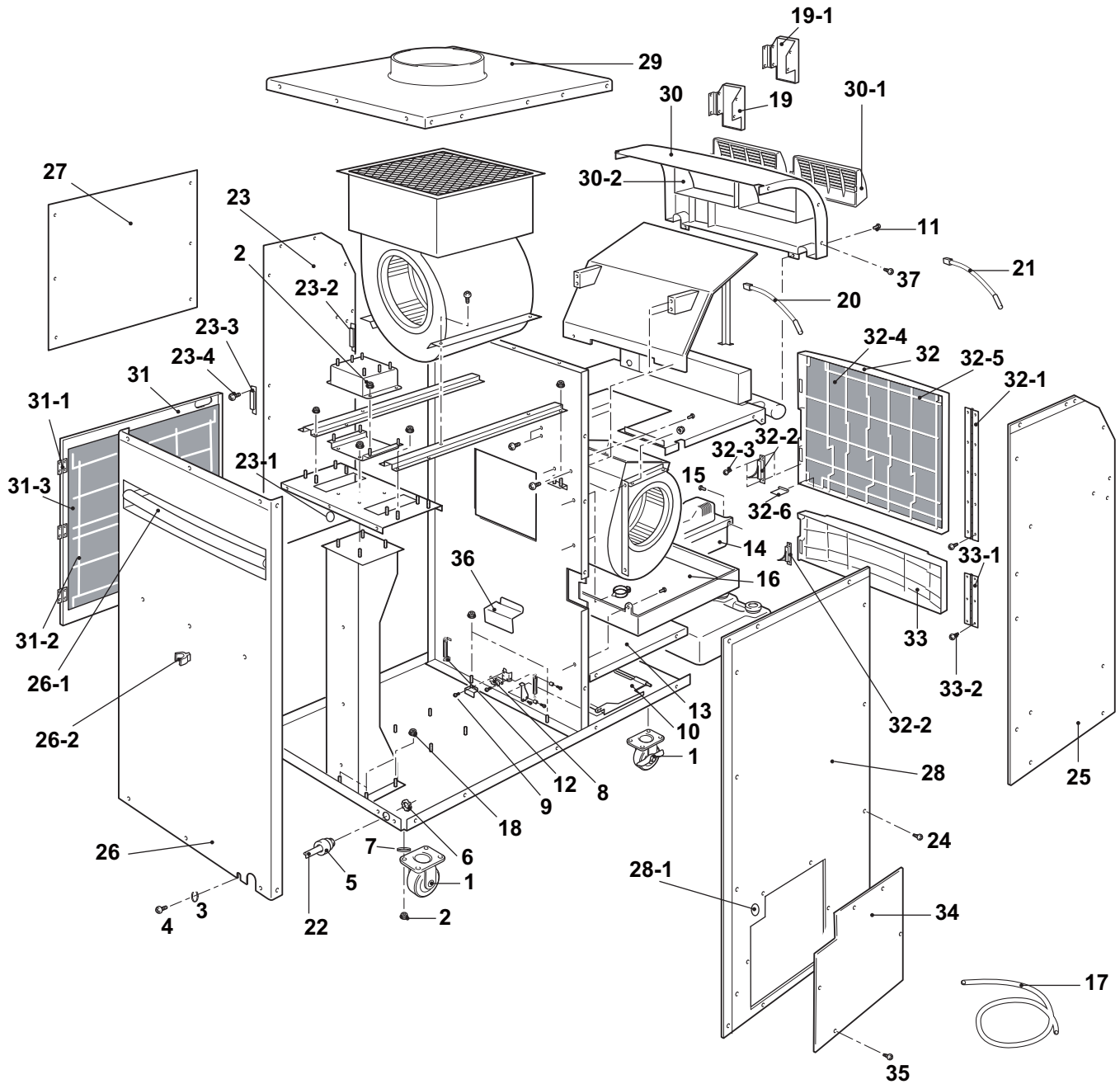

OFFICE PRO 60

ILL. NO.	DESCRIPTION	PART NO.	QTY.	MODIFICATION DATE (mm/yy)	REMARKS
31	Panel Assy, Side Filter	GX484410-8250	1		w/ILL.NO.31-1~31-3
31-1	Hinge	GX484912-0100	1		For Condenser Panel
31-2	Filter (Condenser)	GX484401-1680	1		
31-3	Wire Frame (Condenser)	GX484301-4730	1		
32	Panel Assy, Front Filter	LA484410-6041	1		w/ILL.NO.32-1~32-6
32-1	Hinge	LA484912-0062	1		For Evaporator Panel
32-2	Holder	LA484927-1010	3		Door Hook
32-3	Screw, Tapping	LA949001-1730	12		D4, L=16
32-4	Filter (Evaporator)	LA484401-1310	1		
32-5	Wire Frame (Evaporator)	LA484310-3430	1		
32-6	Clip	LAY84917-0050	2		Holder, Wire Frame
33	Panel Assy	LA484410-6051	1		Drain Tank Door w/ILL.NO.33-1~33-2
33-1	Hinge	LA484912-0071	1		For Drain Tank Door
33-2	Bolt	LA480919-0320	19		
34	Panel Assy, Service	GX484410-8260	1		
35	Screw w/Washer	480919-0370	9		M4×0.7, L=10
36	Cover Sub-Assy	LAY84390-0010	1		
37	Bolt	LA480919-0330	10		M6×1, L=12

OFFICE PRO 60

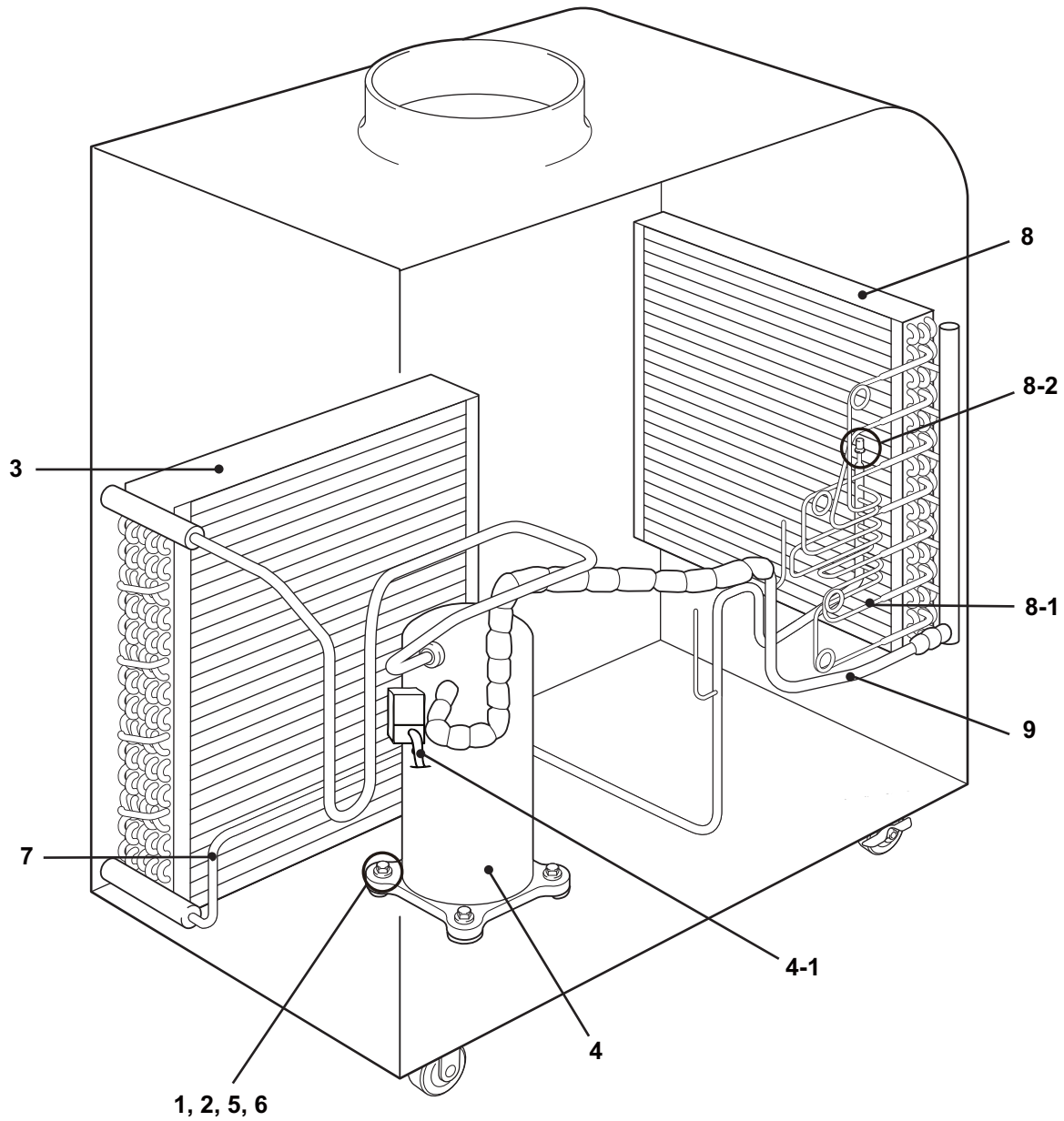

OFFICE PRO 60

ILL. NO.	DESCRIPTION	PART NO.	QTY.	MODIFICATION DATE (mm/yy)	REMARKS
1	Washer, Steel Plate	949011-5330	4		
2	Nut	90190-08651	4		M8×1.25
3	Core Assy, Condenser	GX484600-2140	1		
4	Compressor Assy	GX484650-2640	1		w/ILL.NO.4-1
4-1	Wire Assy	GX484930-9040	1		
5	Cushion	LA484904-0220	4		
6	Collar	LA484915-0280	4		
7	Pipe Assy, Connecting	GX484800-4100	1		For Discharge
8	Core Assy, Evaporator	GX484600-2160	1		w/ILL.NO.8-1~8-2
8-1	Pipe Assy, Capillary	GX484800-4110	1		
8-2	Switch Assy, Pressure	GX484660-0550	1		
9	Pipe Assy, Connecting	GX484800-4210	1		For Suction

OFFICE PRO 60

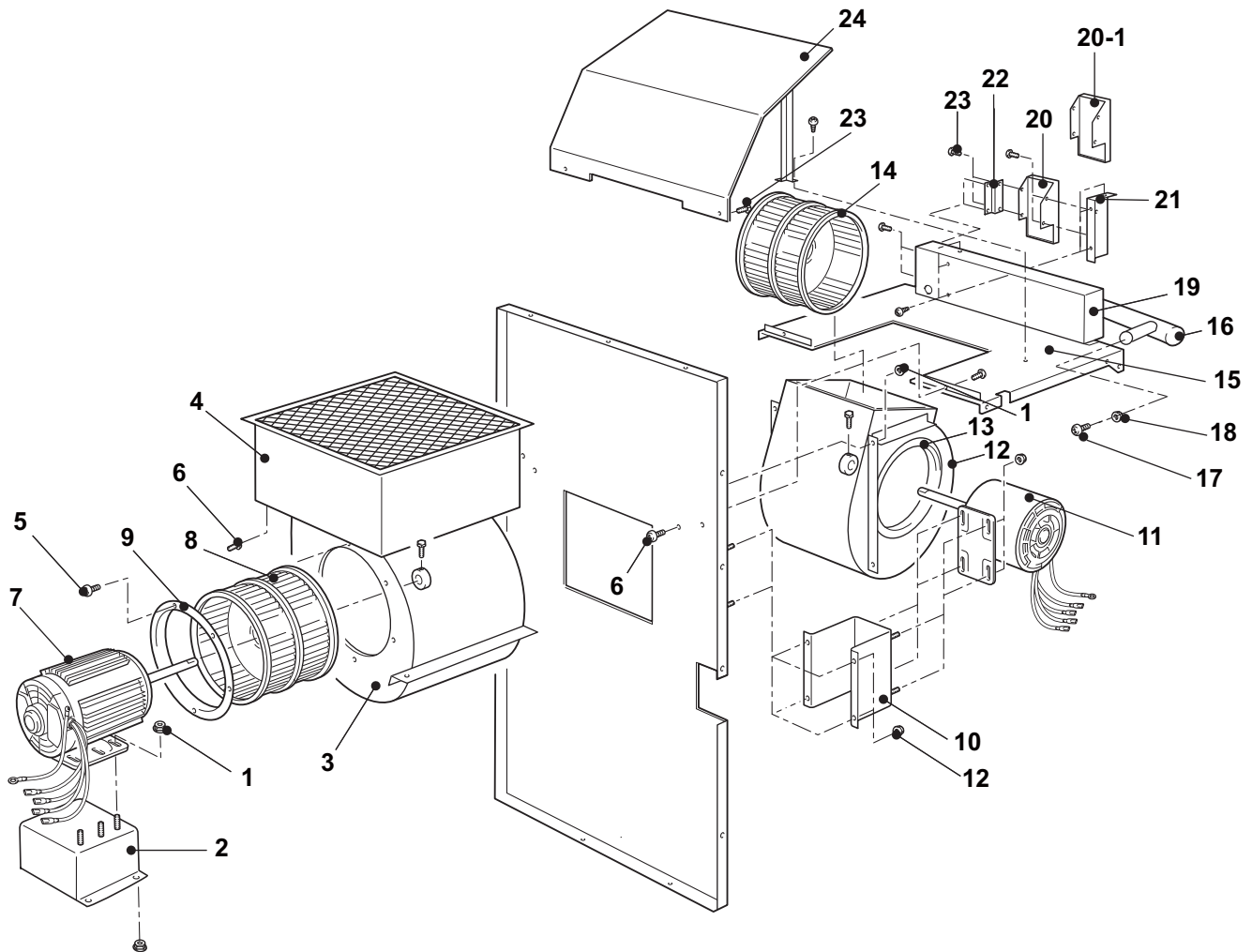

OFFICE PRO 60

ILL. NO.	DESCRIPTION	PART NO.	QTY.	MODIFICATION DATE (mm/yy)	REMARKS
1	Nut	949056-1430	26		M6×1
2	Motor Stay, Condenser	GX484330-0620	1		
3	Casing Assy, Condenser Fan	LA484260-0360	1		
4	Box Sub-Assy, Condenser	LA484520-0840	1		
5	Screw, Tapping	949001-1570	24		D4, L=10
6	Screw w/Washer	91370-06141	4		M6×1, L=14
7	Fan Motor, Condenser	LA484211-1501	1		
8	Fan, Condenser	LA484221-0450	1		w/Set Screw
9	Ring	LA484381-0540	2		For Condenser
10	Motor Stay, Evaporator	LA484330-053A	1		
11	Motor, Evaporator	LA484211-1492	1		
12	Casing Assy, Evaporator Fan	LA484260-0340	1		
13	Ring	LA484381-0530	2		For Evaporator
14	Fan, Evaporator	LA484221-0440	1		w/Set Screw
15	Frame Sub-Assy	LA484310-3420	1		
16	Handle, Front	LA484451-0080	1		
17	Bolt	LA480919-0300	2		For Handle M10×1.5, L=20
18	Washer, Spring	90258-10001	2		For Handle
19	Box Sub-Assy	LA484520-0820	1		
20	Switch Assy	GX484560-1812	1		Operation Panel & PCB w/ILL.NO.20-1
20-1	Cover Assy	GX484420-0510	1		Operation Panel
21	Stay, Control Panel Left	GX484340-3060	1		
22	Stay, Control Panel Right	GX484331-9380	1		
23	Screw	949006-5850	9		M4×0.7, L=10
24	Deflector, Air	LA484310-3450	1		

OFFICE PRO 60

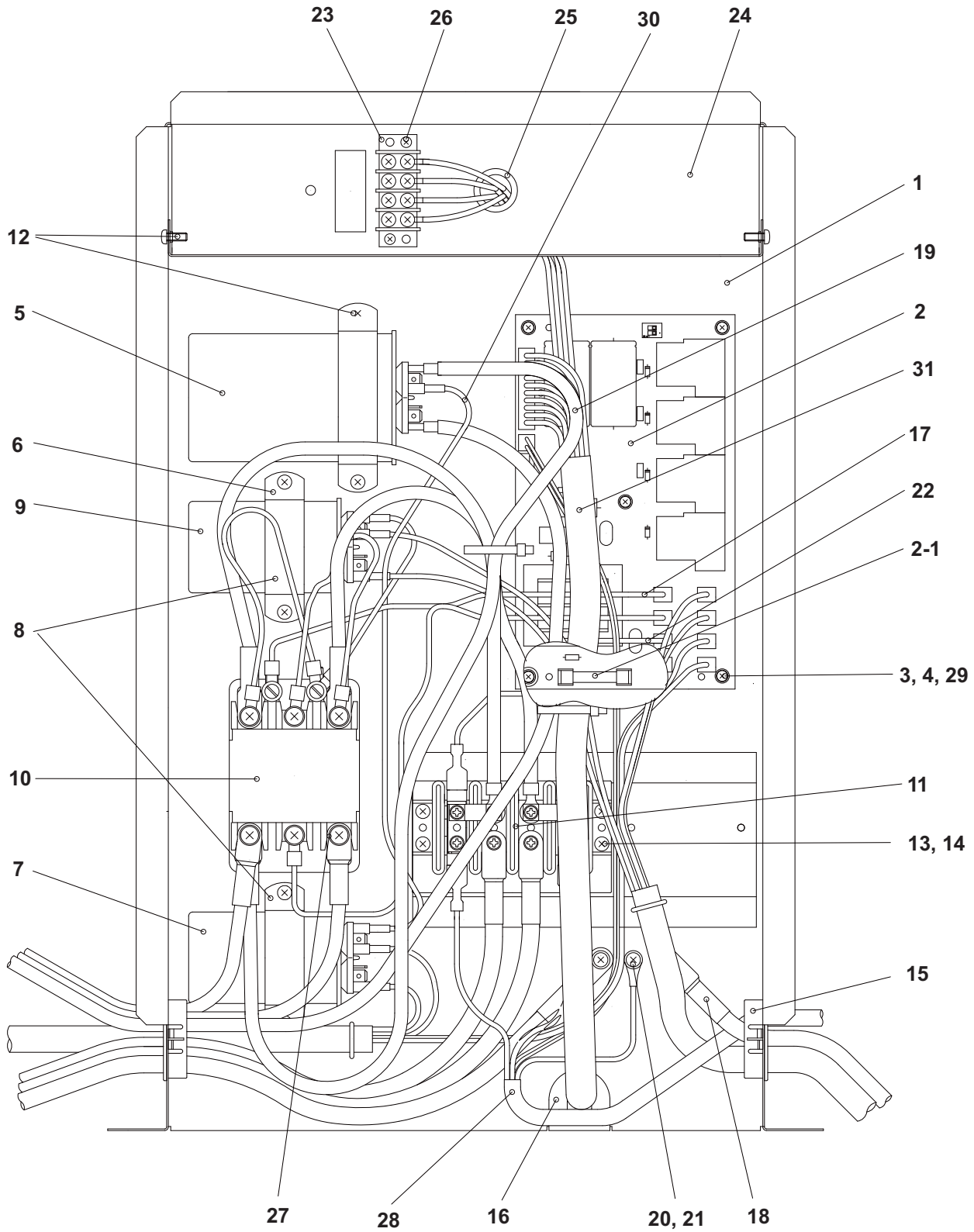

OFFICE PRO 60

ILL. NO.	DESCRIPTION	PART NO.	QTY.	MODIFICATION DATE (mm/yy)	REMARKS
1	Box Sub-Assy	GX484520-1080	1		
2	Relay Board	LA484500-2291	1		w/ILL.NO.2-1
2-1	Fuse, Relay Board	LAY65765-0010	1		200mA, 250V
3	Spacer	LA484921-0150	5		
4	Screw w/Washer	91370-03081	5		M3×0.5, L=8
5	Capacitor, Compressor	GX484507-1670	1		370VAC, 80μF
6	Holder	LA484927-1020	1		
7	Capacitor, Condenser Fan	LA484507-1180	1		370VAC, 25μF
8	Holder	LA484927-0880	2		
9	Capacitor, Evaporator Fan	LA484507-1210	1		440VAC, 15μF
10	Relay	GX484531-0770	1		
11	Terminal Block	LA484503-0551	1		For Power
12	Screw	949006-3250	10		M4×0.7, L=10
13	Washer, Plate	90200-04331	8		
14	Screw	949006-3280	8		M4×0.7, L=18
15	Grommet	LA484926-0600	3		
16	Grommet	484926-0290	1		
17	Wire Assy	GX484930-9081	1		
18	Wire Assy	LA484930-6311	1		
19	Wire Assy	GX484930-9090	1		Evaporator Fan Capacitor
20	Screw	91051-04100	3		Ground (M4×0.7, L=10)
21	Washer, Plate	90201-04300	3		Ground
22	Wire Assy	LA484930-523A	1		(TB)↔(RB)
23	Terminal Block	GX484503-0840	1		For Input/Output Signal
24	Bracket	GX484321-3150	1		
25	Grommet	LA484926-0500	1		
26	Screw w/Washer	91310-03161	2		M3×0.5, L=16
27	Washer, Plate	90201-05300	6		
28	Wire Assy	GX484930-9070	1		Pump
29	Washer, Plate	90200-03211	5		
30	Wire Assy	GX484930-9350	1		Condenser Fan Capacitor
31	Wire Assy	GX484930-9062	1		Main Harness (RB)↔(CB)

[Memo]

OFFICE PRO 60

Unit Part No: LA484000-2500

Production Period: From May 2001 (0501)
To March 2007 (0307)

OFFICE PRO 60

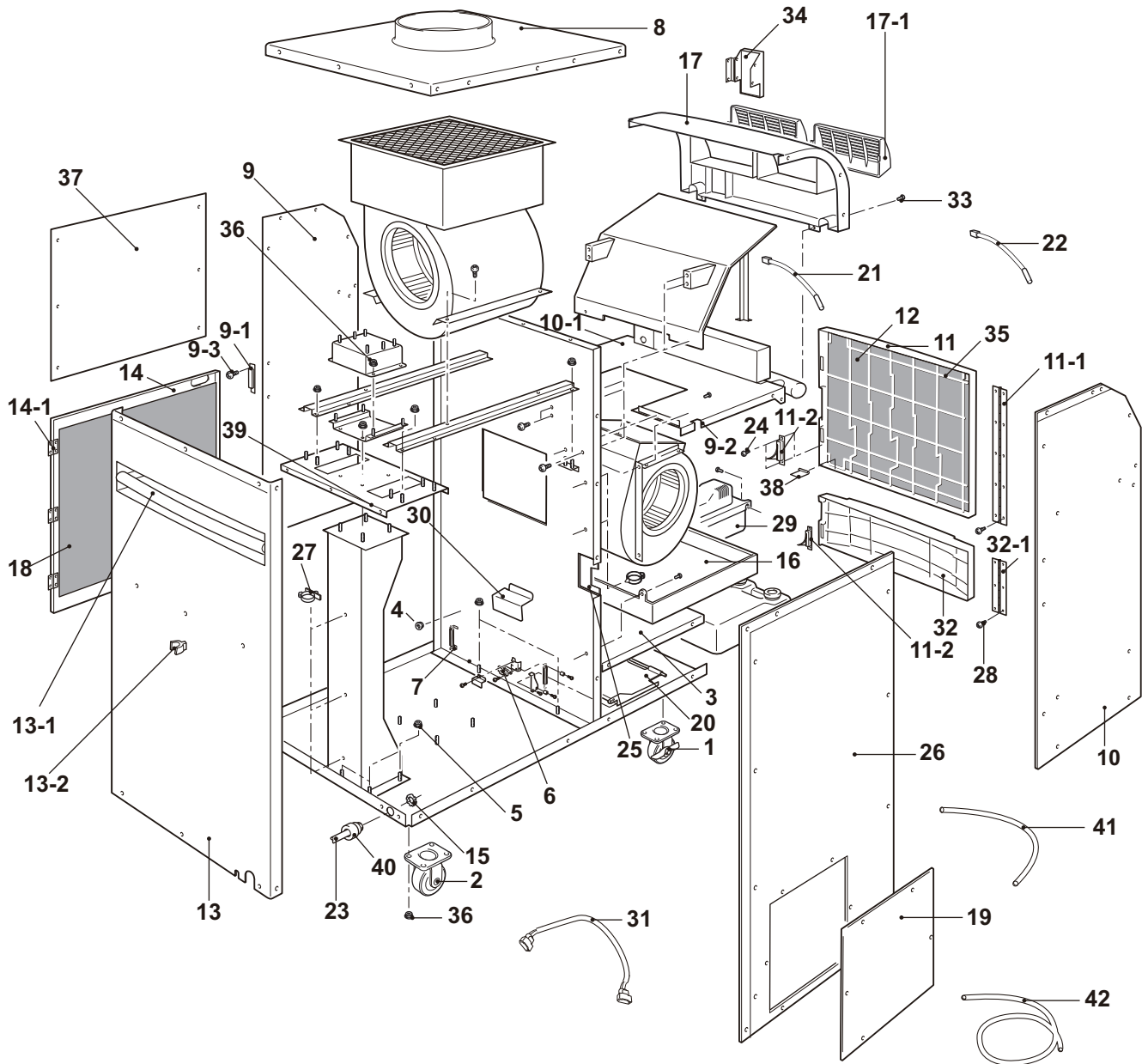

OFFICE PRO 60

ILL. NO.	DESCRIPTION	PART NO.	QTY.	MODIFICATION DATE (mm/'yy)	REMARKS
1	Caster w/Brake	LA484702-0350	2		
2	Caster	LA484702-0270	2		
3	Frame Sub-Assy	LA484300-1662	1		
4	Grommet	LA484926-0500	1		
5	Nut	949056-1430	4		M6×1.0
6	Switch Assy, Drain Tank	LA484502-0380	1		
7	Spring, Tension Coil	484917-0280	2		
8	Panel, Top	LA484410-6010	1		
9	Panel, Right	LA484410-5961	1		
9-1	Holder (Magnet Type)	484927-0990	2		
9-2	Grommet	484926-0290	2		
9-3	Screw	949006-4440	4		M3×0.5, L=8
10	Panel, Left Side Front	LA484410-5970	1		w/12 Screws
10-1	Grommet, Thermistor	949320-5270	1		
11	Panel Assy, Front Filter (Evap.)	LA484410-6041	1		w/Packing, Pins, Hinge & Filter
11-1	Hinge, Evaporator Panel	LA484912-0062	1		
11-2	Door Holder (Male)	LA484927-1010	4		
12	Filter (Evap.)	LA484401-1310	1		
13	Panel, Rear	LA484470-2881	1		
13-1	Handle	LA484451-0080	1		w/2 Bolts
13-2	Power Cord Clip	LA484917-042A	2		
14	Panel Assy, Side Filter (Cond.)	LA484410-6030	1		w/Velcro and Filter
14-1	Hinge, Condenser Panel	LA484912-0050	3		
15	Retainer, Power Cord	LA484919-0090	1		
16	Drain Pan Assy	LA484430-0410	1		
17	Panel, Front Top	LA484410-6021	1		
17-1	Air Louver, Outlet	LA480431-0101	2		
18	Filter (Condenser)	LA484401-1310	1		
19	Panel, Service	LA484410-6060	1		
20	Pivot Panel	LA484430-1650	1		
21	Thermistor, Room Temp.	LAY84532-0021	1		
22	Thermistor, Anti-Freeze Up	LA484532-0041	1		
23	Power Cord Assy	LA484930-634C	1	From 01/'02	
		LA484930-634B	1	To 12/'01	
24	Screw, Tapping	949001-1730	1		D4, L16
25	Grommet, Pipe	484926-0610	1		
26	Panel, Left Side Rear	LA484410-6001	1		
27	Clip	LAY84917-0010	3		
28	Screw	LA480919-0320	4		M4×0.7, L=8
29	Condensate Pump	LA484780-0160	1		
30	Cover, Drain Switch	LAY84390-0010	1		w/Packing
31	Wire Harness	LA484930-628A	1		(RB)↔(CB)

OFFICE PRO 60

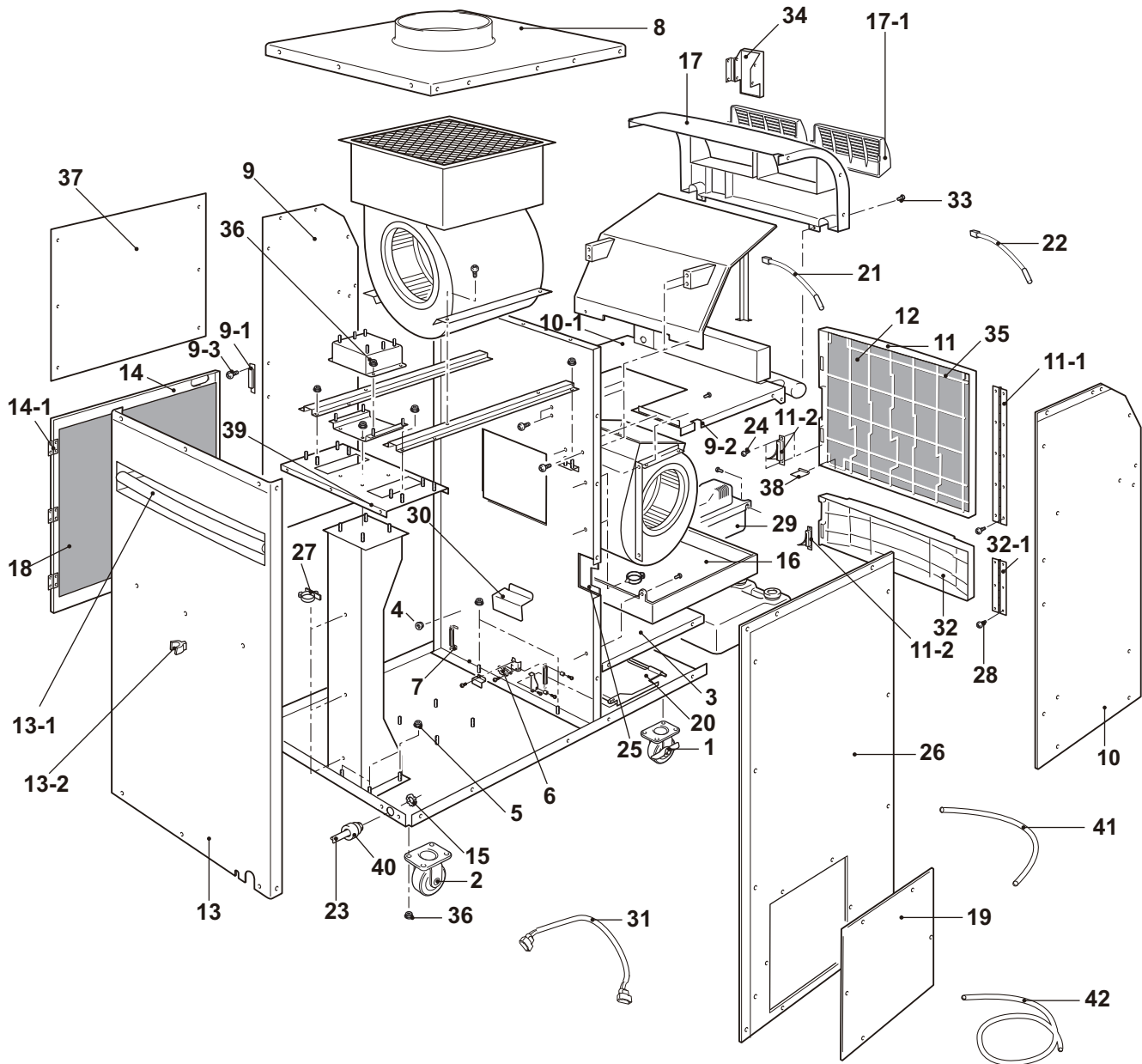

OFFICE PRO 60

ILL. NO.	DESCRIPTION	PART NO.	QTY.	MODIFICATION DATE (mm/yy)	REMARKS
32	Condensate Pump Access Door	LA484410-6051	1		
32-1	Hinge	LA484912-0071	2		
33	Screw	949006-5850	8		M4×0.7, L=10
34	Switch Assy	LA484560-1551	1		Operation Panel & PCB
35	Frame, Evaporator Filter	LA484310-3430	1		Evaporator
36	Nut	LA480929-0140	16		w/Washers (M10×1.5)
37	Panel Assy, Right Top Rear	LA484410-5991	1		
38	Clip	LAY84917-0050	1		
39	Grommet	LA484926-0500	1		
40	Connector	LA484784-002A	1		Power Cord
41	Drain Hose	LAY84433-0010	1		w/Clip
42	Hose, Drain - Pump	LA484432-0190	1		Beckett

OFFICE PRO 60

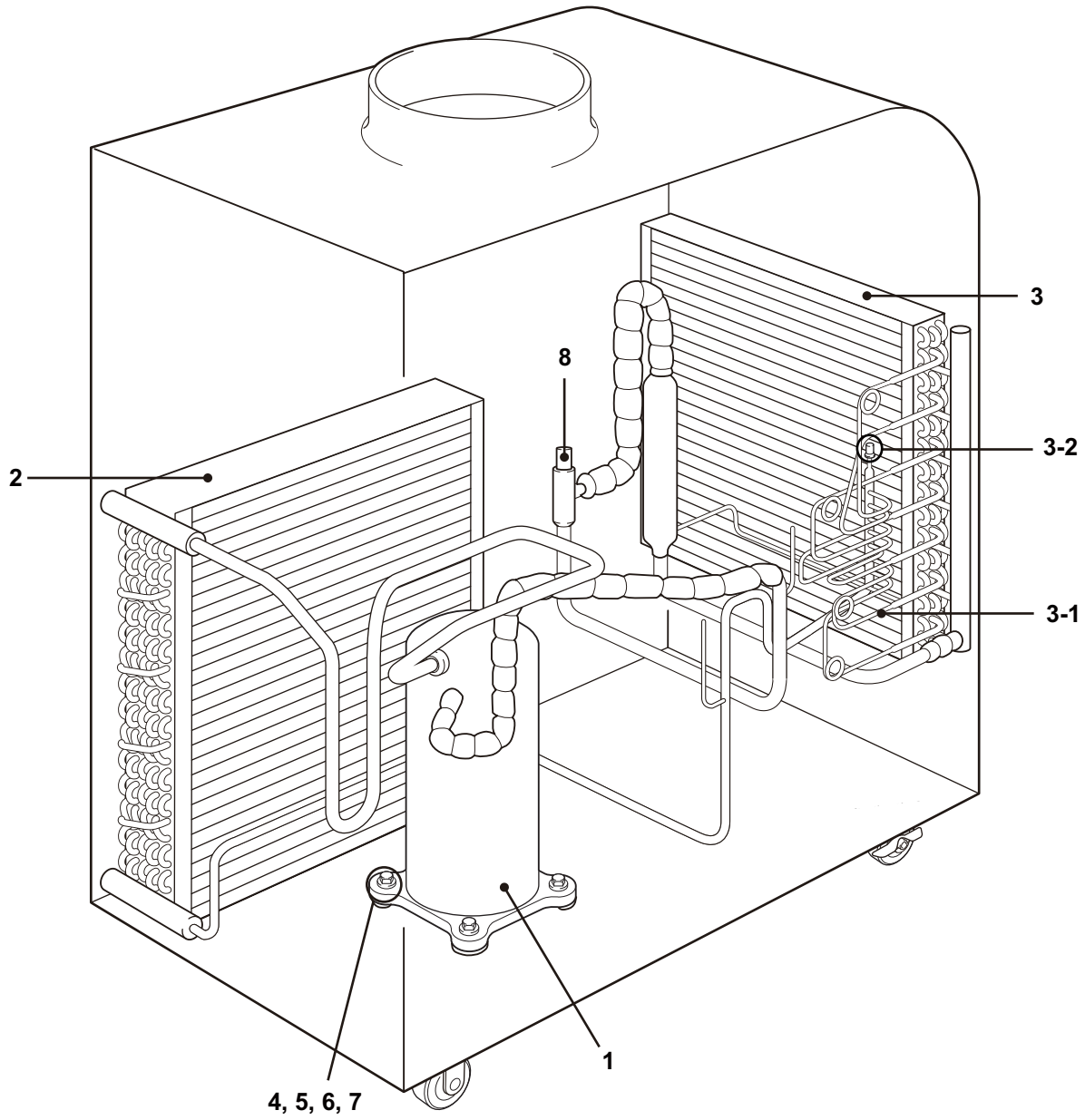

OFFICE PRO 60

ILL. NO.	DESCRIPTION	PART NO.	QTY.	MODIFICATION DATE (mm/yy)	REMARKS
1	Compressor Assy	LA484650-1651	1		
2	Core Assy, Condenser	LA484600-1561	1		w/Pipes
3	Core Assy, Evaporator	LA484600-1571	1		w/Capillary Tube & Pressure Switch w/ILL.NO.3-1~3-2
3-1	Pipe Assy, Capillary	LA484800-3231	1		
3-2	Switch Assy, Pressure	LA484660-0420	1		w/Tube
4	Cushion	LA484904-0220	4		
5	Collar	LA484915-0280	4		
6	Washer, Steel Plate	949011-5330	4		
7	Nut	90190-08651	4		M8×1.25
8	Pressure Regulator	LA484782-014A	1		SPR

OFFICE PRO 60

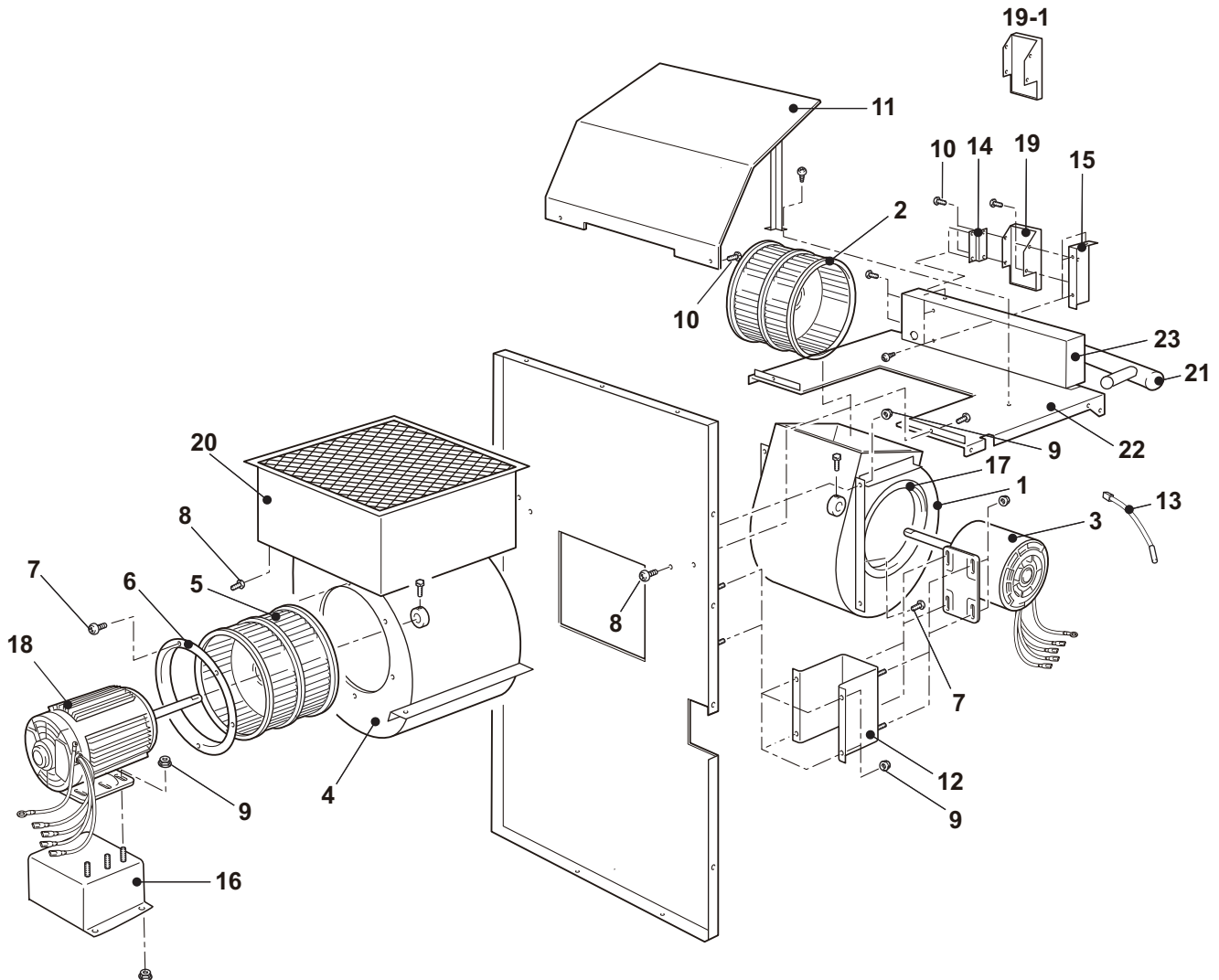

OFFICE PRO 60

ILL. NO.	DESCRIPTION	PART NO.	QTY.	MODIFICATION DATE (mm/yy)	REMARKS
1	Casing, Evaporator Fan	LA484260-0340	1		
2	Fan, Evaporator	LA484221-0440	1		w/Bolt
3	Fan Motor (Evaporator)	LA484211-1492	1		
4	Casing Assy, Condenser Fan	LA484260-0360	1		
5	Fan, Condenser	LA484221-0450	1		w/Bolt
6	Ring, Condenser	LA484381-0540	2		
7	Screw, Tapping	949001-1570	24		D4, L=10
8	Screw w/Washer	91370-06141	6		M6×1, L=14
9	Nut	949056-1430	14		M6×1
10	Screw	949006-5850	1		M4×0.7, L=10
11	Deflector, Air	LA484310-3450	1		
12	Evaporator Motor Stay	LA484330-053A	1		
13	Thermistor Anti-Freeze	LA484532-0041	1		
14	Stay, Control Panel Right	LA484331-7450	1		
15	Stay, Control Panel Left	GX484340-3150	1		Stay Front
16	Condenser, Motor Stay Assy	LA484330-0550	1		Assembly w/6 Bolts
17	Ring, Evaporator	LA484381-0530	2		
18	Motor, Condenser	LA484211-1501	1		
19	Switch Assy	LA484560-1551	1		Operation Panel & PCB w/ILL.NO.19-1
19-1	Cover Assy	GX484420-0570	1		Operation Panel
20	Box Assembly, Condenser	LA484520-0840	1		
21	Handle	LA484451-0080	1		
22	Frame	LA484301-3220	1		
23	Box	LA484520-0820	1		

OFFICE PRO 60

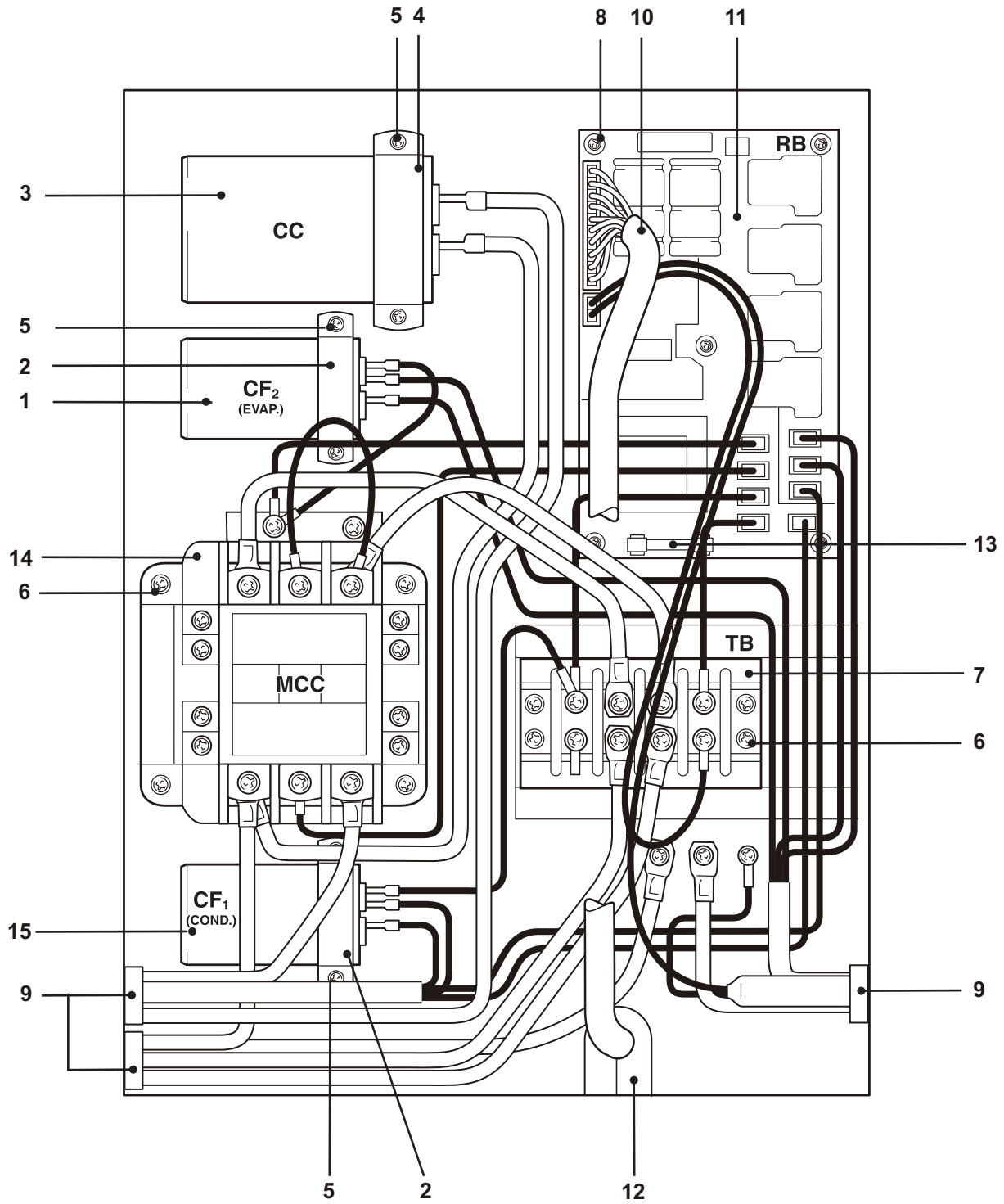

OFFICE PRO 60

ILL. NO.	DESCRIPTION	PART NO.	QTY.	MODIFICATION DATE (mm/yy)	REMARKS
1	Capacitor, Fan Evaporator	LA484507-1210	1		440VAC, 15 μ F
2	Holder	LA484927-0880	2		
3	Capacitor, Compressor	LA484507-1170	1		370VAC, 70 μ F
4	Holder	LA484927-1020	1		
5	Screw	949006-3250	6		M4 \times 0.7, L=10
6	Screw	949006-3280	8		w/Washer (M4 \times 0.7, L=18)
7	Terminal Block	LA484503-0551	1		(TB)
8	Screw	91370-03081	5		w/Washer (M3 \times 0.5, L=8)
9	Grommet	LA484926-0600	3		
10	Wire Assy	LA484930-628A	1		(CB) \leftrightarrow (RB)
11	Relay Board Assy	LA484500-2291	1		(RB) 230V
12	Grommet	484926-0290	1		
13	Fuse, Relay Board	LAY65765-0010	1		200m Amps 250 Volts
14	Relay, Compressor	LA484531-0560	1		
15	Capacitor, Fan Condenser	LA484507-1180	1		370VAC, 25 μ F

DENSO

DENSO SALES CALIFORNIA, INC.

Long Beach, CA 90810

www.movincool.com

Second Issue: April 2008