



Portable Air Cooled Air Conditioners

Office Pro 63

Cooling Capacity	Btu/hr. @ 95°	
	At 60% Relative Humidity	60,000
Dimensions	Width (Inches)	30
	Depth (Inches)	52
	Height (Inches)	64
	Weight (Pounds)	705
	Shipping Weight	835
Electrical Characteristics	Power Supply (Volts)	460/3
	Power Consumption (Kilowatts)	6.6
	Current Consumption (Amperes)	9.5
	Fuse Size (Amperes)	20
	NEMA Plug Configuration	L16-20
	Min-max Voltage	440-480 Volt
	Power Cord Gauge	12AWG (4 Core)
	Power Cord Length (Feet)	6
Compressor Characteristics	Compressor Type	Hermetic Scroll
	Refrigerant	R-410A
	Operating Conditions: Min-max °F	65°-105°F
Fan Characteristics	<i>Evaporator:</i>	
	Fan Type	Centrifugal
	Air Flow (CFM) High/Low	1940/1770
	Max. External Static Pressure (Inches Of Water Gauge)	0.9
	<i>Condenser:</i>	
	Fan Type	Centrifugal
	Air Flow (CFM) High/Low	2830/2650
Max. External Static Pressure (Inches Of Water Gauge)	0.85	
Safety Devices	Compressor Overload Relay	Yes
	Fan Motor Protection	Yes
	Anti-freeze Thermostat	Yes
	Automatic Tank Shut-off	N/A
	Condensate Tank Capacity (Gallons)	Auto Pump Included
	High-pressure Switch	Yes
	Compressor Short-cycle Protection	Yes
	Fan Mode Switch	Yes
	Automatic Restart	Yes
	Thermostat	Yes
Control Panel	Programmable	
	Thermostat Control	Electronic
Miscellaneous Features	Humidity Removed @ 60% RH	3.04
	Accommodates Condensate Pump	Included
	Sound Level (Db) High/Low	69/67
	Max Evaporator Ducting Length*(Ft.)	40
	Max Condenser Ducting Length*(Ft.)	100
	<i>*subtract 10 Ft. For Every 90° Bend</i>	



Portable Air Cooled Air Conditioners

Office Pro 63

Power Supply 460 volts 60 hertz 3 phase 9.5 amperes

Width 30 inches

Depth 52 inches

Height 64 inches

Weight (net/shipping) lbs 705/835

All models are backed by a 12-month warranty with 36 months for the compressor.
All coils are treated with an acrylic resin coating for extended life and corrosion resistance.

TOP

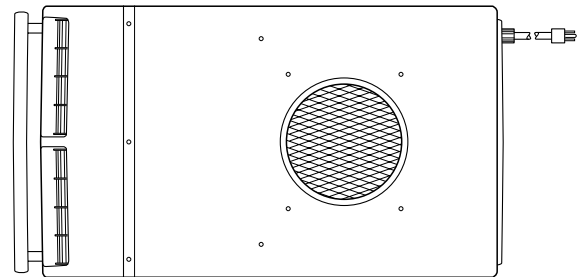

FRONT

30"

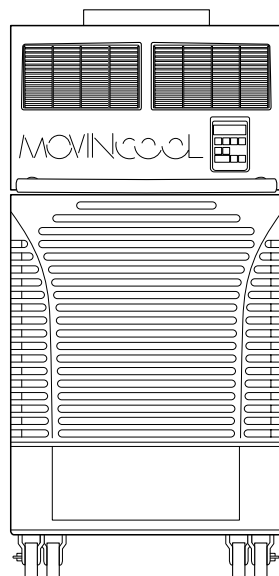

SIDE

52"

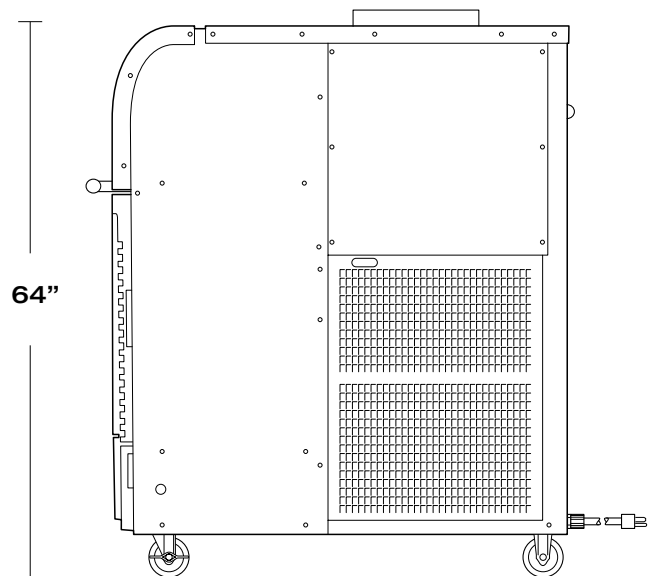

64"