



# Industrial CO<sub>2</sub> transcritical pack systems

Power COOL<sub>2</sub>



Brochure



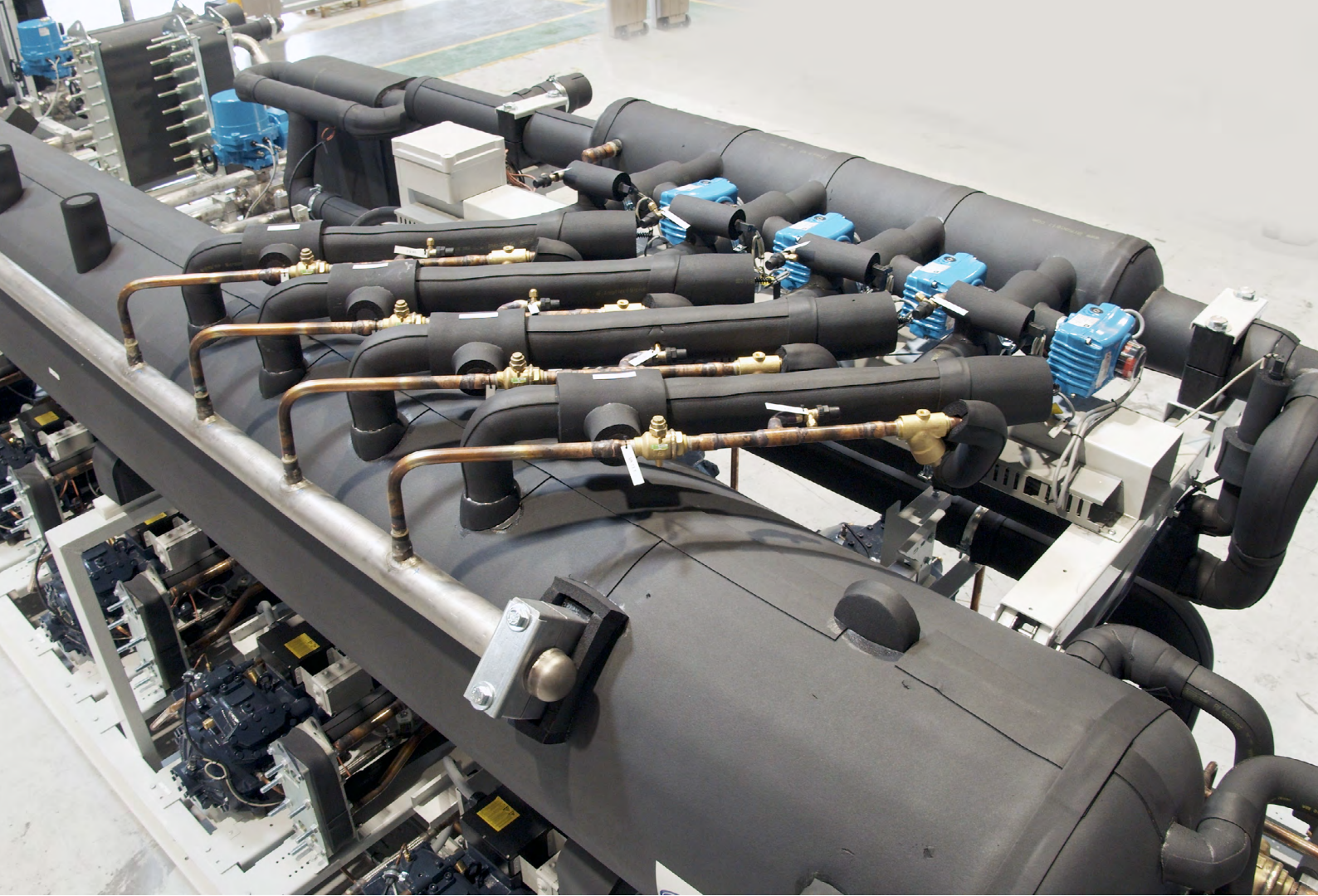



# Summary

<b>Main applications</b>	<b>4</b>	<b>Heat reclaim possibilities</b>	<b>10</b>
<b>Preserving and recovering energy</b>	<b>5</b>	▪ Enthalpy diagram of a heat recovery system	10
▪ Preserving the environment	5	<b>Possible configurations</b>	<b>11</b>
▪ Optimizing energy consumption	5	<b>Operating principles</b>	<b>13</b>
▪ Recovering the heat produced	5	▪ Modulating vapor ejector	13
▪ Easier to use	5	▪ Intermediate compression stage	13
▪ User-friendly and connected control interface	5	▪ Suction line heat exchanger (SLHX)	13
▪ Faster approval, more incentives	5	▪ Semi-flooded mode	13
▪ Wide range of applications	5	▪ CO <sub>2</sub> pump	13
<b>Applications / Configurations / Temperatures</b>	<b>6</b>	▪ Heat recovery	13
▪ Temperature range	6	▪ PLC Controller	13
<b>Components and connection points</b>	<b>7</b>	▪ Receivers:	13
<b>Patented vapour ejector and system</b>	<b>8</b>	▪ Auxiliary condensing unit	13
▪ Component	8	<b>PLC interface and electrical enclosure</b>	<b>14</b>
▪ System	8	▪ Download the app	14
▪ Ejector advantages	8	▪ Electrical cabinet	14
<b>Patented lift and shift “Easy for service”</b>	<b>9</b>	▪ Control	14

# Main applications

## Warehouse & Distribution centers

- Warehouse
- Medium and low temperature
- Cold storage



- Competitive first investment and reduced service and maintenance cost
- Non-corrosive refrigerant; no risk for electric and electronic equipment
- Lower weight; reducing building and structural investment
- Hot gas defrost as an option for best possible energy performance

## Process and Pharma

- Food processing
- Meat processing
- Plastic industry



- Versions for pump assisted CO<sub>2</sub> secondary systems available
- Multiple heat recovery functions and heat pump versions available
- Compact, preassembled indoor and outdoor housed pack configurations for minimum on-site installation time

## Sport venues

- Ice rink
- Ski arena



- Refrigerant allowed for use in public areas
- Direct expansion in the ice floor improving energy efficiency
- Precise control of ice quality
- Efficient heat recovery, high, medium and low grade flow specifically adapted for sports arenas

## Heat reclaim and Chiller

- Domestic hot water
- Heating & hot water production
- District heating
- Comfort cooling A/C



- High grade flow temperature, up to 90 °C in standard version
- Non-flammable refrigerant
- Small footprint kW/m<sup>2</sup>
- High COP



# Preserving and recovering energy



## Preserving the environment

- GWP CO<sub>2</sub>= 1
- Not flammable
- Not toxic
- Not corrosive
- No PFAS



## User-friendly and connected control interface

- Latest generation of PLC (programmable logic controller) with large touchscreen
- Embedded communication module
- Monitoring through webserver and smartphone app
- Included 4G router for remote commissioning and service



## Optimizing energy consumption

- Up to 30% energy savings versus standard CO<sub>2</sub> systems
- Modulating vapor ejector (lower energy consumption, better temperature control)



## Faster approval, more incentives

- No special approval needed from local authorities
- Eligible for incentives & subsidies in lots of European countries



## Recovering the heat produced

- Up to 100% heat recovery (sanitary hot water and hot water for heating)
- Up to 2 MW of free heat
- 4 levels of heat recovery (up to 90°C, 45-60°C, 15-20°C)



## Wide range of applications

- Distribution centers
- Food Processes
- Sport venues
- Heat pumps



## Easier to use

- High-capacity with 1 rack
- Cooling capacity up to 700 kW LT\*
- Cooling capacity up to 1.5 MW MT\*
- Possibility to reach higher capacity by combining racks
- Lift & shift (S/M)



\* LT @-32°C / 37°C GC outlet  
MT @-6°C / 37°C GC outlet



# Applications / Configurations / Temperatures

PowerCO<sub>2</sub>OL: a solution adapted to all your needs

MT = Medium Temperature | LT = Low Temperature | DX = Direct Expansion

Configurations	PowerCO <sub>2</sub> OL MT DX	PowerCO <sub>2</sub> OL MT Chiller	PowerCO <sub>2</sub> OL MT+LT DX	PowerCO <sub>2</sub> OL LT DX	PowerCO <sub>2</sub> OL MT Chiller + LT DX	PowerCO <sub>2</sub> OL MT (DX+Chiller) +LT DX
Applications	Power 1	Power 2	Power 3	Power 4	Power 5	Power 6
Distribution center	✓	✓	✓	✓		
Warehouse	✓	✓	✓	✓		
Hypermarket	✓	✓	✓			
Food processing	✓	✓	✓	✓	✓	✓
Tunnel freezer			✓	✓		
Heating	✓	✓	✓	✓	✓	✓
Air conditioning		✓				
Sport venues	✓	✓				
Ice rink	✓	✓				

Configuration	Power 1	Power 2	Power 3	Power 4	Power 5	Power 6
Cooling capacity MT* (kW)	200-1500	200-1250	350-1100	-	300-900	300-900
Cooling capacity LT* (kW)	-	-	100-700	200-700	100-700	100-700
Heating capacity (kW)	2200	1950	1650	1350	1400	1400
MT compressors	8	8	6	6	6	6
LT compressors	0	0	6	6	6	6

\* @-6°C(MT)/-32°C(LT)/37°C (gas cooler outlet) for DX configuration

@-8/-4°C(Chiller)/37°C (gas cooler outlet) for Chiller

@+4°C(MT)/ 30-85°C Water temp for heat reclaim

## Temperature range

Ambient condition	Gascooler outlet	Evaporating temperature	PowerCO <sub>2</sub> OL MT DX	PowerCO <sub>2</sub> OL MT Chiller	PowerCO <sub>2</sub> OL MT+LT DX	PowerCO <sub>2</sub> OL LT DX	PowerCO <sub>2</sub> OL MT Chiller + LT DX	PowerCO <sub>2</sub> OL MT (DX+Chiller) +LT DX	
			Power 1	Power 2	Power 3	Power 4	Power 5	Power 6	
-35°C to +43°C	Min: +5°C/40bar  Design point: +38°C/97bar  Max: +45°C/102 bar	MT	Min.	-20°C	-20°C	-20°C	optimized by control	-20°C	-20°C
			Design point	-4°C	-4°C	-4°C		-4°C	-4°C
			max.	+4°C	+4°C	+4°C		+4°C	+4°C
		LT	Min.			-45°C	-45°C	-45°C	-45°C
			Design point			-32°C/ -4°C	-32°C/ -4°C	-32°C/ -4°C	-32°C/ -4°C
			max.			-20°C	-20°C	-20°C	-20°C

**Note:** Power5: Open flash + separate Chiller module.



# Components and connection points

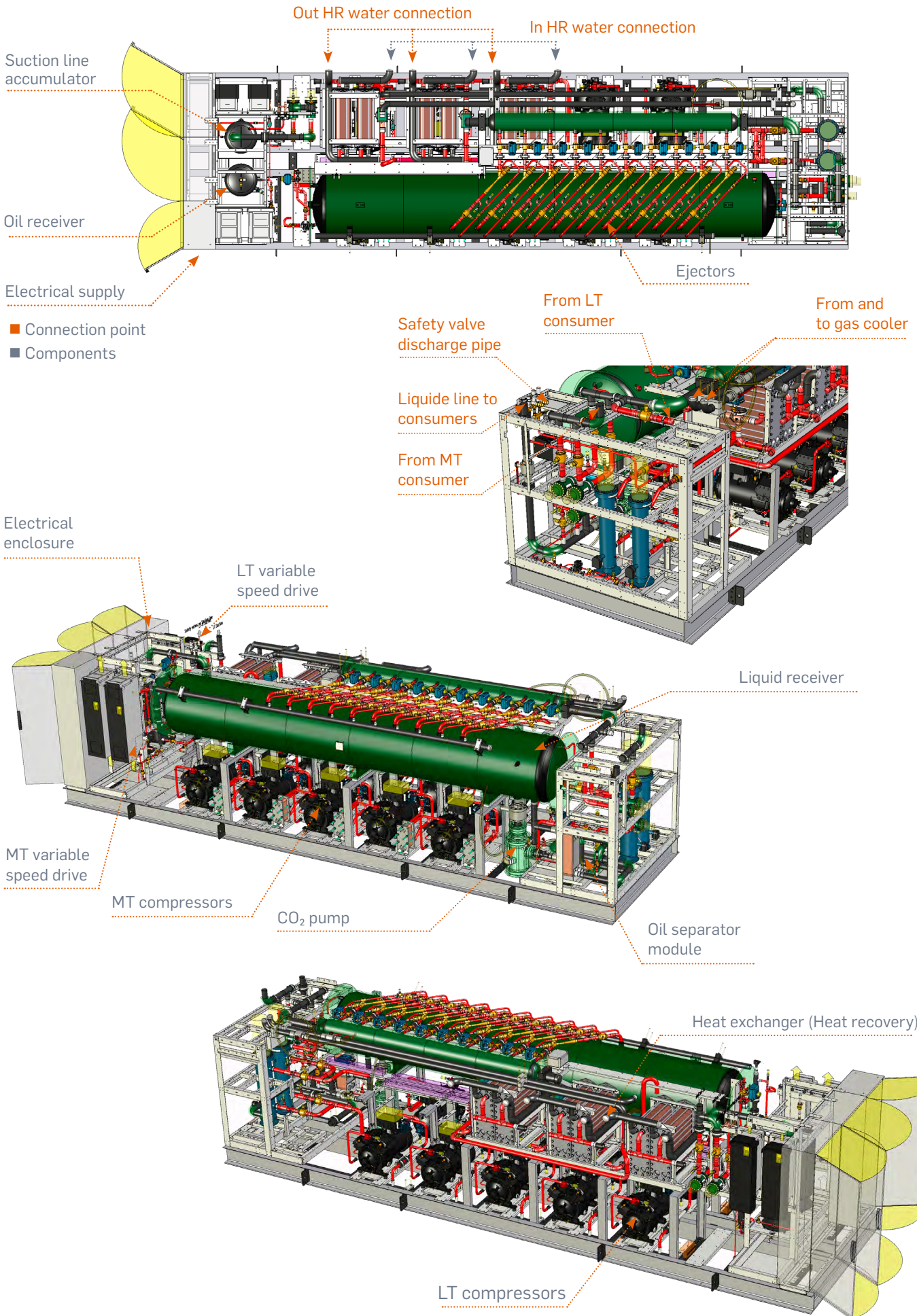



# Patented vapour ejector and system

Our PowerCO<sub>2</sub>OL range is equipped with the latest modulating ejector technology. This enables us to operate the compressors at a higher suction pressure while maintaining the cooling condition required from the system. In combination with flooded evaporator operation enabled by the PowerCO<sub>2</sub>OL system design, the units provide significantly improved COP and reduced energy consumption. The system is designed to be compact while accessible with indoor and outdoor versions available. PowerCO<sub>2</sub>OL can operate as a chiller or direct expansion solution with all components selected and designed for high system resilience.

## Component

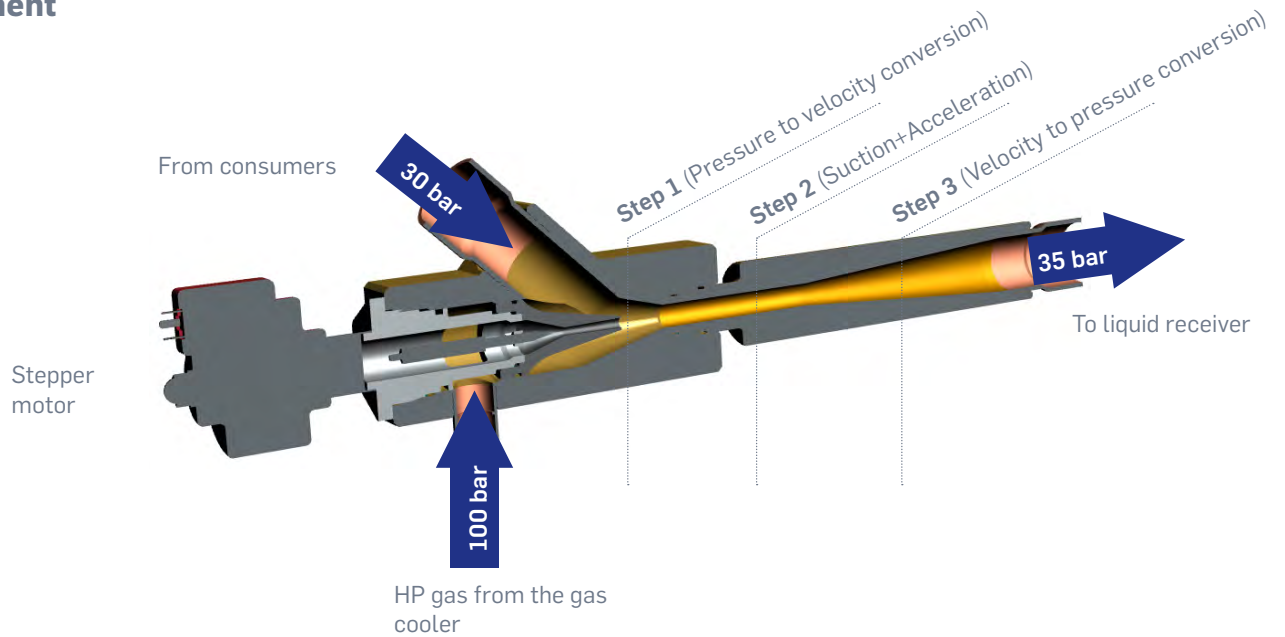

## System

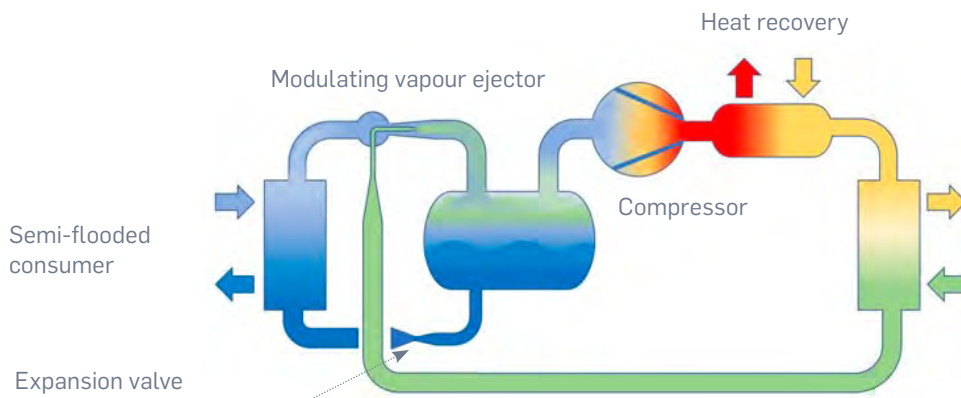

## Ejector advantages

### Standard transcritical system

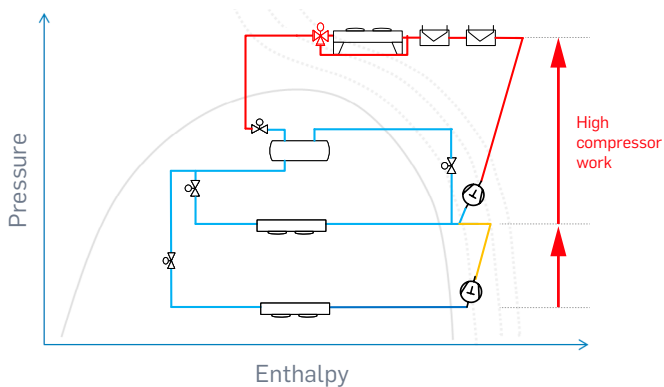

### PowerCOOL<sub>2</sub>

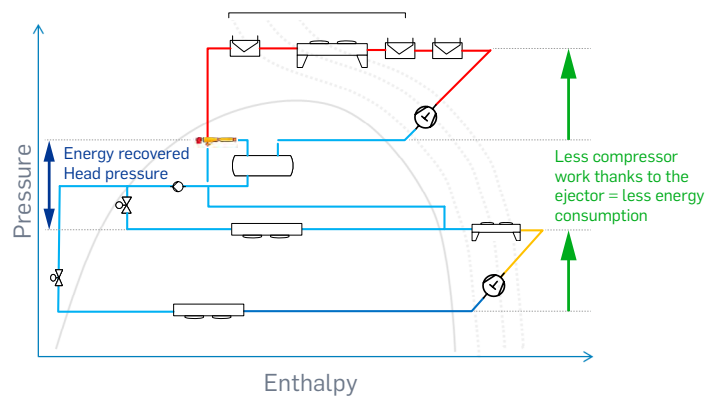

# Patented lift and shift “Easy for service”

Dealing with large refrigerant systems featuring multiple heavy compressors can pose a challenge when it comes to servicing a compressor. To simplify this task, Carrier patented the user-friendly tool “Lift and Shift.” This innovative tool streamlines the process, making it effortless to move compressors in and out of the frame with minimal manpower and straightforward steps.

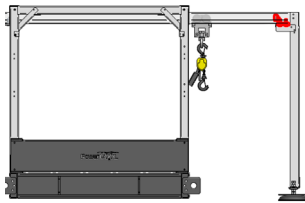

**1** Assemble the lift & shift tool

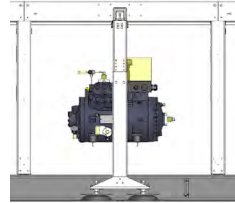

**2** Attach the hoist to hook of the compressor

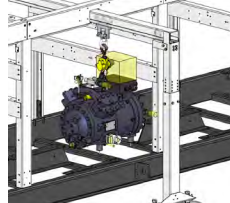

**3** Slide the compressor on the rail out of frame

## Quick & Easy Service

- Compressor Change within 30 minutes by 1 person
- Reduced maintenance cost
- Small service space required
- Load up to 500kg





# Heat reclaim possibilities

## HE10

- High grade heat recovery (sanitary hot water)

## HE20

- Medium grade heat recovery (Heating)

## HE30

- Air cooled gas cooler

## HE40

- Low grade heat recovery (floor heating)

## HE130

- Low grade heat recovery (floor heating)

## Enthalpy diagram of a heat recovery system

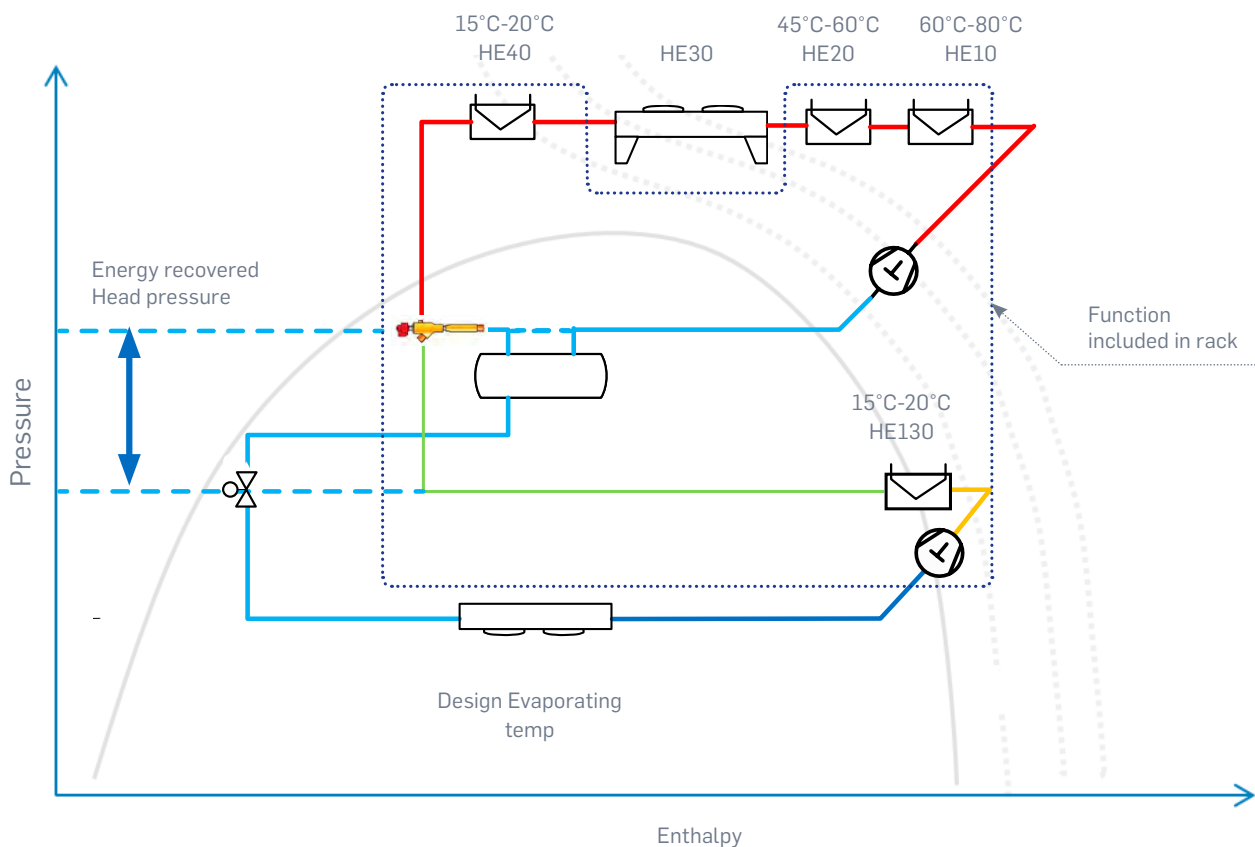

# Possible configurations

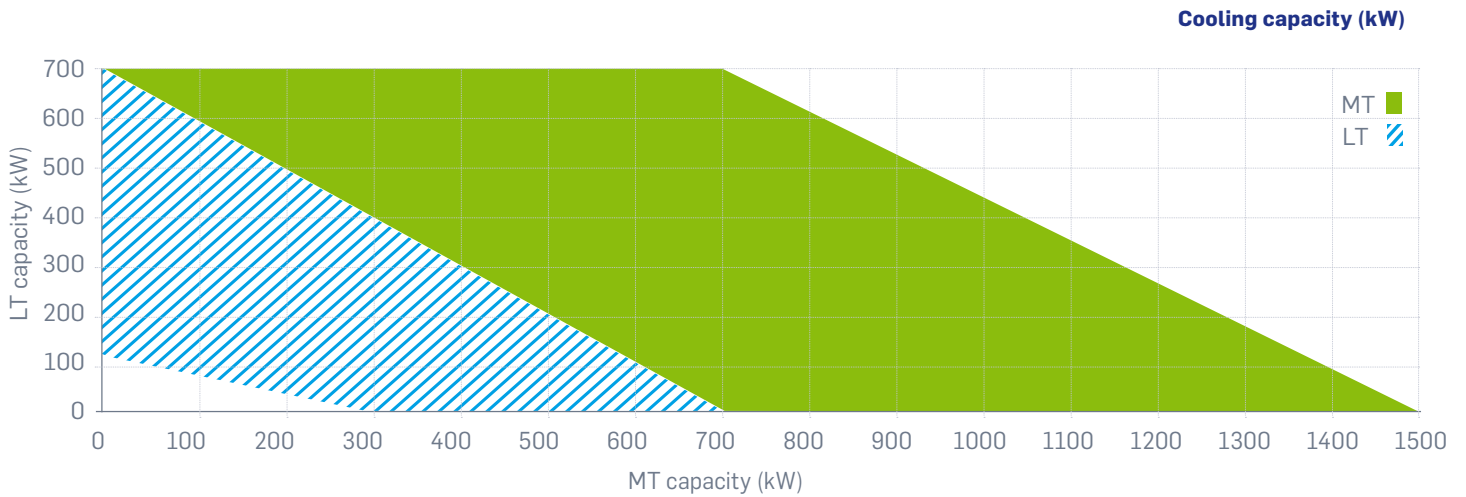

## Power 1 PowerCO<sub>2</sub>OL MT DX

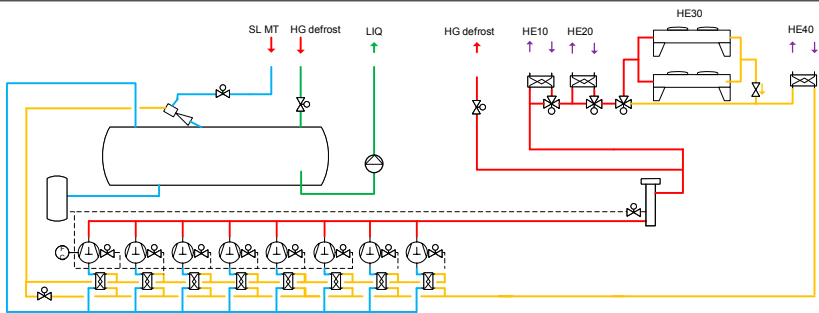

### Cooling capacity

@ -6°C/37°C (gas cooler outlet)

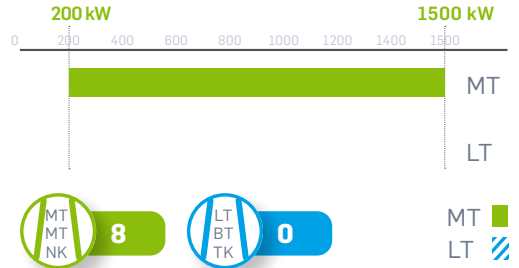

## Power 2 PowerCO<sub>2</sub>OL MT Chiller

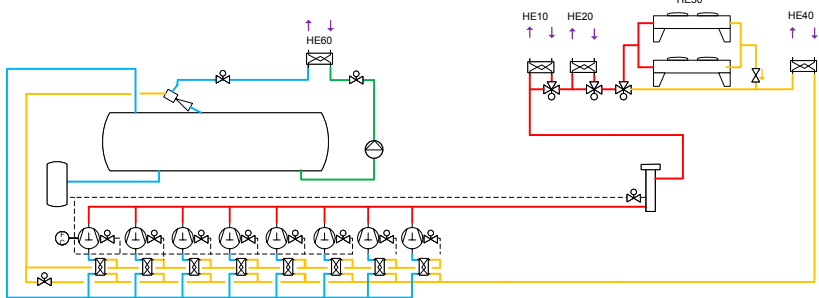

### Cooling capacity

@ -8/-4°C(Chiller)/37°C (gas cooler outlet) for Chiller

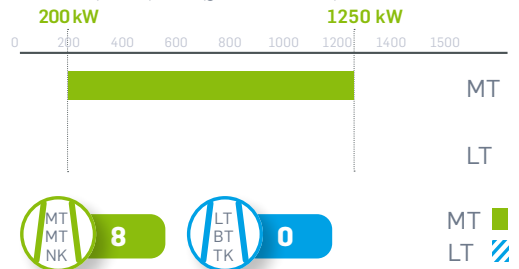

## Power 3 PowerCO<sub>2</sub>OL MT+LT DX

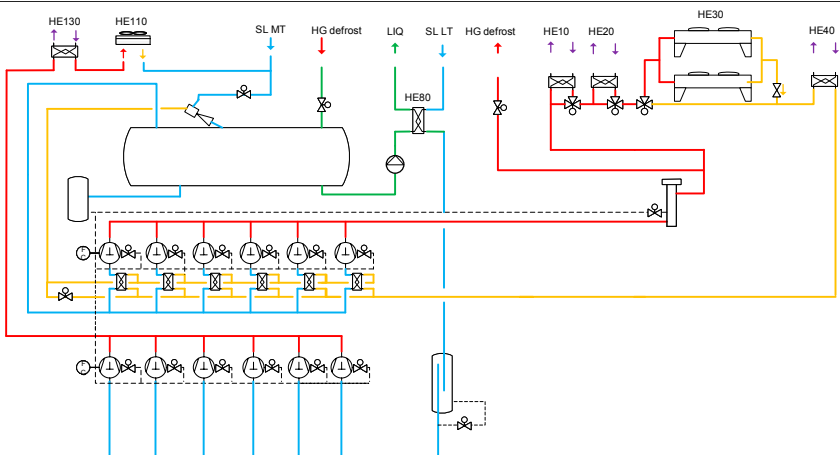

### Cooling capacity

@ -6°C(MT)/-32°C(LT)/37°C (gas cooler outlet)

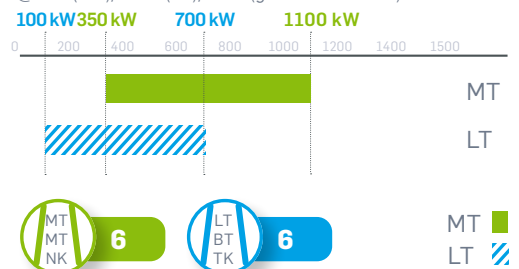



**Power 4**

**PowerCO<sub>2</sub>OL LT DX**

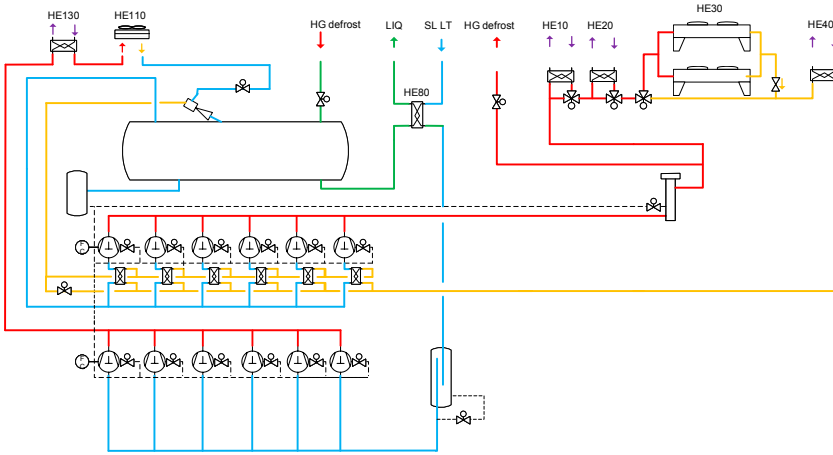

**Cooling capacity**

@-32°C(LT)/37°C (gas cooler outlet)

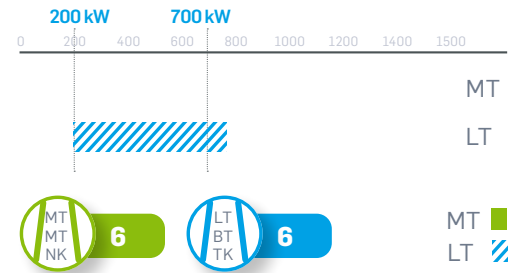

MT ■  
LT ▨

**Power 5**

**PowerCO<sub>2</sub>OL MT Chiller + LT DX**

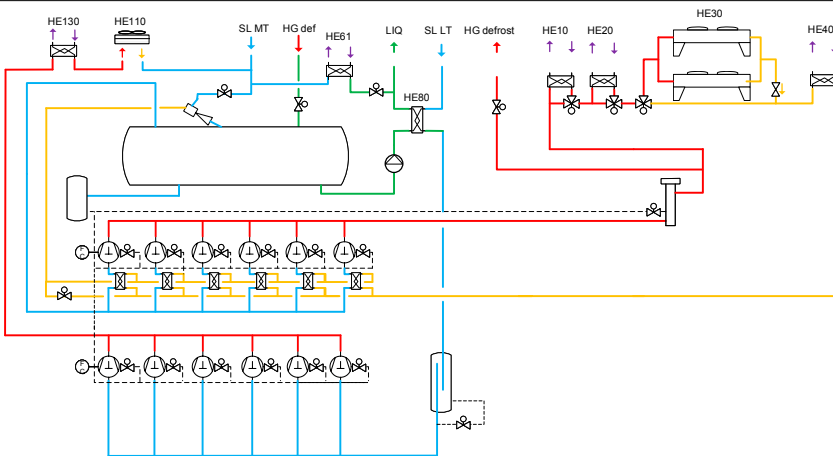

**Cooling capacity**

-8°C/-4°C(Chiller)/-32°C(LT)/37°C (gas cooler outlet)

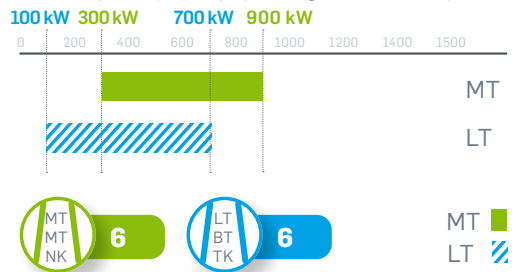

MT ■  
LT ▨

**Power 6**

**PowerCO<sub>2</sub>OL MT (DX+Chiller) + LT DX**

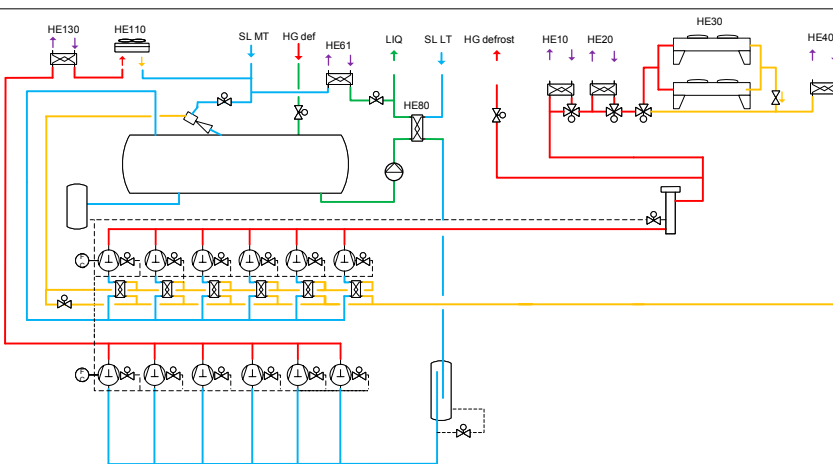

**Cooling capacity**

@-6°C(MT)/ -8°C/-4°C(Chiller) /-32°C(LT)/37°C (gas cooler outlet)

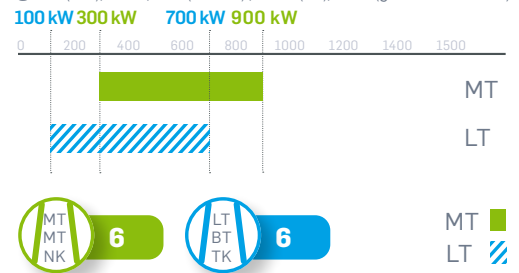

MT ■  
LT ▨

# Operating principles

In addition to using a neutral and natural refrigerant for the planet, PowerCO<sub>2</sub>OL products integrate the latest innovative technology in order to enhance the energy efficiency and to minimize the carbon footprint linked to their use. The PowerCO<sub>2</sub>OL differentiates itself from a standard transcritical solution in the following way:



## Modulating vapor ejector

- On this range of machines there is no HP (high pressure) valve or MP (medium pressure) valve. The modulating vapor ejector recovers the energy from the high pressure circuit (coming from the gas cooler) to pre-compress the vapors coming from the MT consumers into the liquid receiver. Thus the ejectors replace the HP valve



## Intermediate compression stage

- The MP stage compressor suction is entirely connected to the receiver. There is no MP expansion device. The pre-compression achieved by the ejectors allows to reduce the MP stage compressor work thus their electrical consumption



## Suction line heat exchanger (SLHX)

- Each rack has its own heat exchanger to subcool the refrigerant exiting the gascooler and to generate superheat reducing the risk of liquid droplets going into the compressor



## Semi-flooded mode

- The use of ejectors allows the MT evaporators operation to be in semi-flooded mode
- To benefits of the semi flooded mode, expansion valve with adapted orifice, set with 1 or 2K superheat are required. Standard evaporators can be used, no need of special coil for flooded mode



## CO<sub>2</sub> pump

- The CO<sub>2</sub> pump is located after the liquid receiver, it is activated to compensate the limited pressure uplift achieved by the ejectors under certain outside temperature/pressure conditions (Winter without heat recovery or intermediate seasons). The pump ensures thus a regular supply to the MT consumers expansion valve
- The CO<sub>2</sub> pump is not operating continuously, it is enabled by the controller only if there is a risk that the expansion valve cannot provide enough cooling capacity

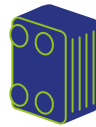

## Heat recovery

- CO<sub>2</sub> and its excellent thermodynamic properties including high discharge gas temperatures, allows to recover up to 100% of the heat generated and on a continuous basis at high temperature. These features mean the system can simultaneously produce heat for space/floor heating and domestic hot water through several heat exchangers. Various configurations are possible with or without bypass gas-cooler and must be equipped with a set of anti boiling bypass valves. Pressure drop on water side calculated lower than 50 kPa



## PLC Controller

- Intuitive HMI graphical display with easy access to running parameters and set points making commissioning, fine tuning and trouble shooting easier
- Built in methods for calculating and displaying cooling capacity, COP, generated heat etc. The PowerCO<sub>2</sub>OL PLC controller helps to improve the installation and energy savings. Cooling/Heat recovery power and energy the connectivity of the installation (individual and combined) are calculated by using compressor polynomials, results are shown as values but also in a live Ph-log diagram
- Compatible with the main communication protocol networks (Modbus, Canbus, Bacnet...)



## Receivers:

- Horizontal receiver
- Insulated with 19mm Armaflex
- Safety valves on 3-way change over valve connected to a common discharge header



## Auxiliary condensing unit

- Recommended only when using plate and gasket evaporator heat exchanger with 60 bar max service pressure



# PLC interface and electrical enclosure

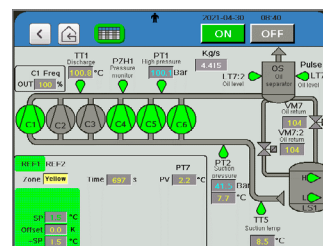
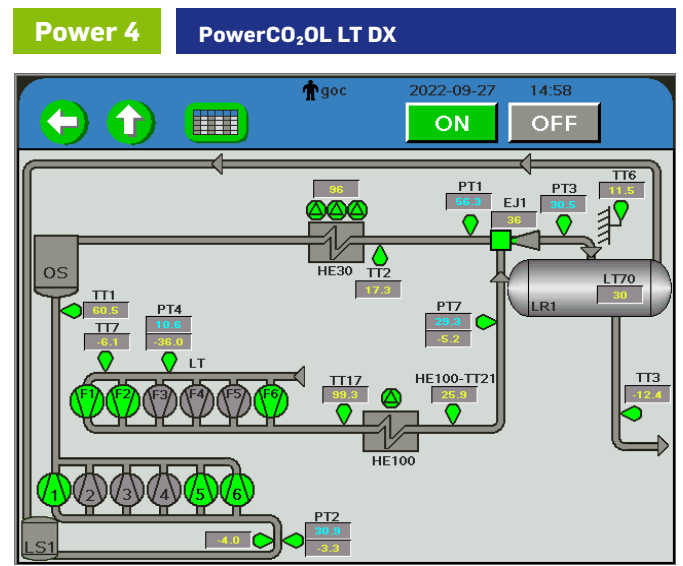
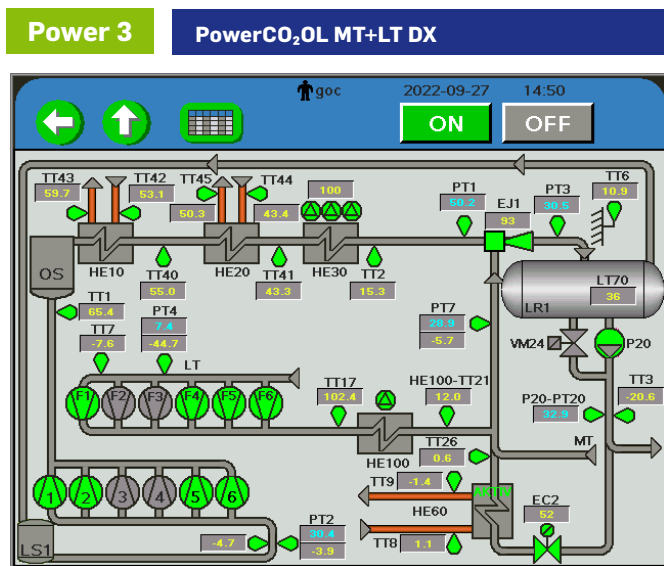

Compressors control

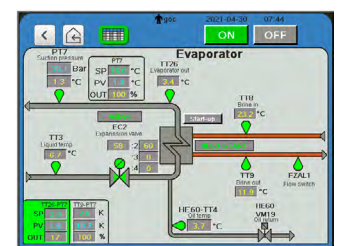

Evaporator control

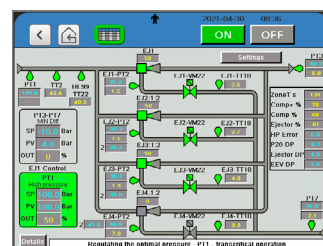

Ejector control

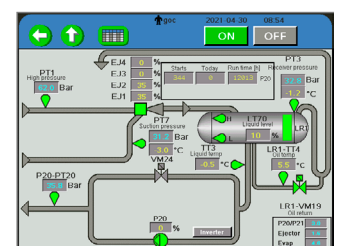

CO<sub>2</sub> pump control

Download the app



## Electrical cabinet

- Power supply
- Contactors
- Thermal protections
- Relays
- Terminal blocks
- Compressor power and management.
- Protection by adjustable thermal-magnetic circuit breaker
- A 400V + N power supply for the gas-cooler box

## Control

- Control units and plant management PLCs
- Interactive touch screen mounted on the front panel
- Heat recovery control with control of 3-way valves and control of the pump on the water circuit
- 0-10V or MODBUS gas cooler fan control



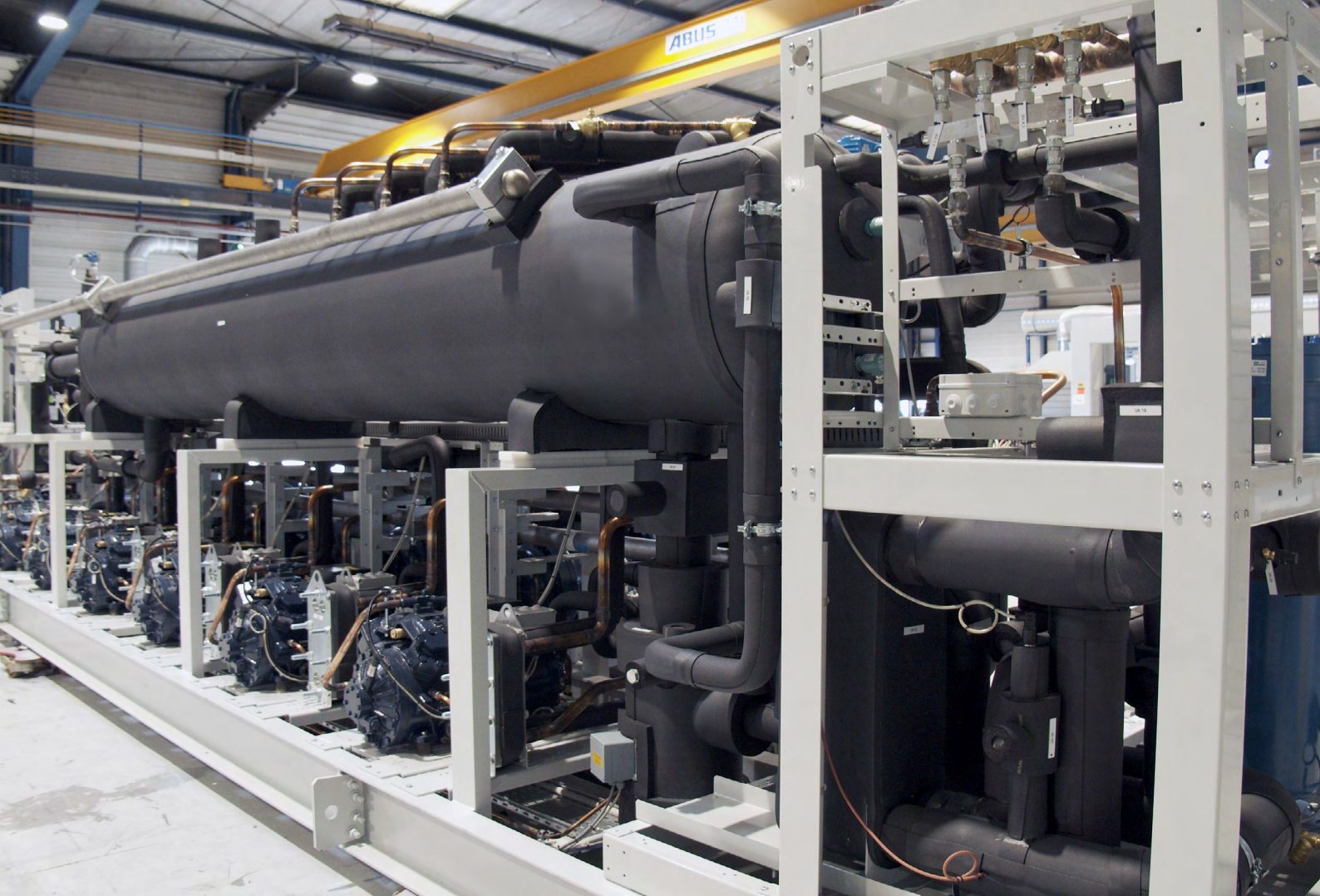



# Proven Solutions. Cooling | Heating Sustainable. Efficient.

## PowerCOOL L

Industrial processes,  
large warehouses



## QuietCOOL

Small stores, extensions



## PowerCOOL S/M

Warehouses,  
food processes



## QuietCOOLMC

Convenience stores



## MaxiCOOL

Hypermarkets



## MiniCOOL

Supermarkets



## HeatCOOL IL

District heating



## HeatCOOL IM

Apartment  
blocks



## HeatCOOL IS

Industry | hotel



## HeatCOOL CM

School | offices | hospital  
commercial building | hotel



- Water source / Air source
- Packaged evaporator / split versions for commercial AW ranges
- Reversible: Heat in winter / AC and domestic hot water in summer

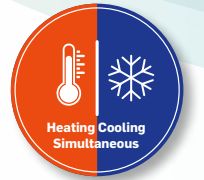
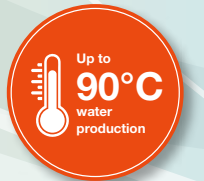

More than  
**20 000**  
units produced



Profroid reserves the right to change certain information and specifications contained in this document at any time and without prior notice. Since standards, specifications and designs are subject to occasional change, please ask for confirmation of the information given in this publication

[www.profroid.com](http://www.profroid.com)



Profroid-PowerCO<sub>2</sub>OL-brochure-en-04.01.2024. All trademarks are the property of their respective owners. ©2024. Profroid. All Rights Reserved.